

Metal framing channels

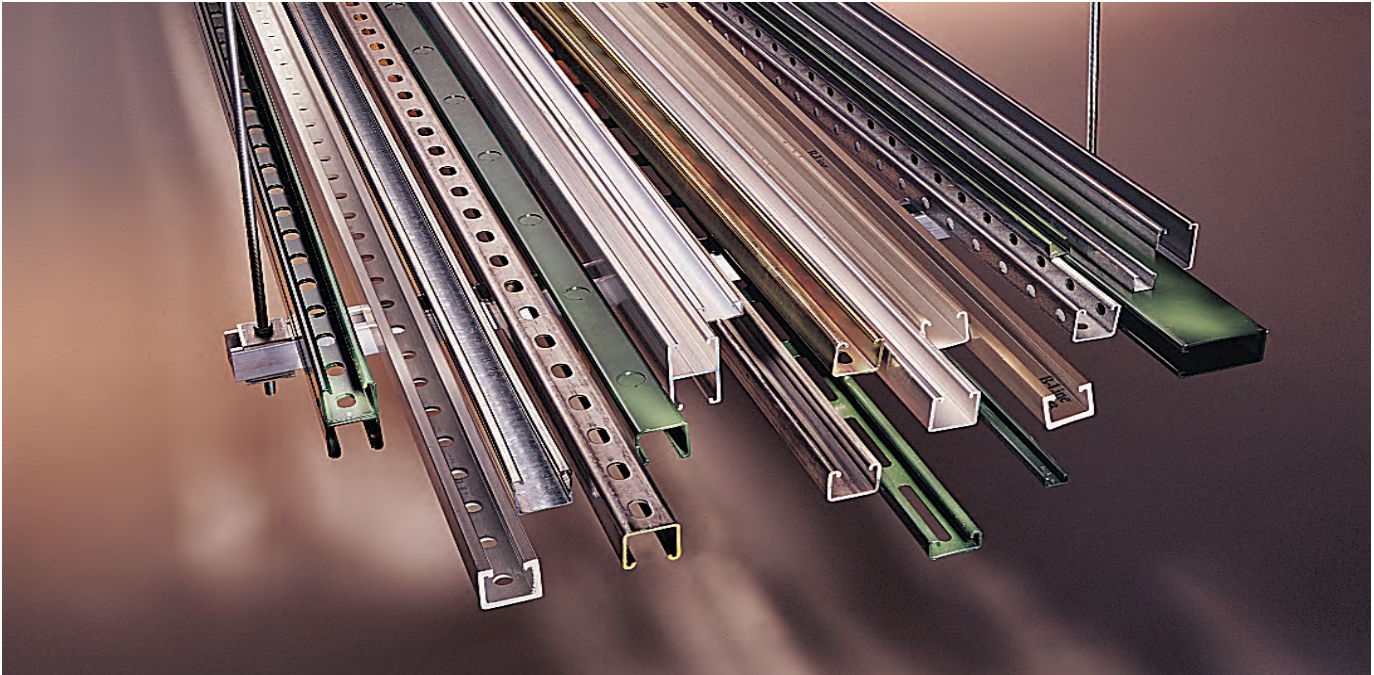

Channel

Metal framing channel is cold formed on our modern rolling mills from 12 Ga. (2.6mm) and 14 Ga. (1.9mm) low carbon steel strips. A continuous slot with inturned lips provides the ability to make attachments at any point.

Lengths & Tolerances

All channels excluding 'SH' style $\pm 1/8"$ (3.2mm) on 10' (3.05m) and $\pm 3/16"$ (4.76mm) on 20' (6.09m)
 All 'SH' channels only $\pm 1/4"$ (6.35mm) on 10' (3.05m) and $\pm 1/2"$ (12.70mm) on 20' (6.09m)
 Custom lengths are available upon request.

Slots

Slotted series of channels offer full flexibility. A variety of pre-punched slot patterns eliminate the need for precise field measuring for hole locations. Slots offer wide adjustments in the alignment and bolt sizing.

Holes

A variety of pre-punched $9/16"$ (14.3 mm) diameter hole patterns are available in our channels. These hole patterns provide an economical alternative to costly field drilling required for many applications.

Knockouts

When used with series B217-20 Closure Strips, knockout channels can be used to provide an economical U.L. listed surface raceway. Channels are furnished with $7/8"$ (22.2 mm) knockouts on 6" (152 mm) centers, allowing for perfect fixture alignment on spans up to 20' (6.09 m).

Materials & Finishes (Unless otherwise noted)

Steel: Plain & Pre-galvanized

12 Ga. (2.6) and 14 Ga. (1.9)

Note: A minimum order may apply on special material and finishes.

Design Load (Steel & Stainless Steel)

The design loads given for strut beam loads are based on a simple beam condition using an allowable stress of 25,000 psi. This allowable stress results in a safety factor of 1.68. This is based upon virgin steel minimum yield strength of 33,000 psi cold worked during rolling to an average yield stress of 42,000 psi. For aluminum channel loading multiply steel loading by a factor of 0.38.

Finish Code	Finish	Specification
PLN	Plain	ASTM A1011, 33,000 PSI min. yield
GRN	DURA GREEN™	
GLV	Pre-Galvanized	ASTM A653 33,000 PSI min. yield
HDG	Hot-Dipped Galvanized	ASTM A123
YZN	Yellow Zinc Chromate	ASTM B633 SC3 Type II
SS4	Stainless Steel Type 304	ASTM A240
SS6	Stainless Steel Type 316	ASTM A240
AL	Aluminum	Aluminum 6063-T6







Welding

Weld spacing is maintained between 2 1/2 inches (63.5 mm) and 4 inches (101.6 mm) on center. Through high quality control testing of welded channels and continuous monitoring of welding equipment, we provide the most consistent combination channels available today.

Metric

Metric dimensions are shown in parentheses. Unless noted, all metric dimensions are in millimeters.

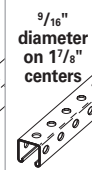
Selection Chart for Channels, Materials and Hole Patterns

Channel Type	Channel Dimensions		Material & Thickness* Stainless Steel				Channel Hole Pattern**				
	Height 	Width 	Steel	Alum.	Type 304	Type 316	SH	S	H1 ⁷ / ₈	TH	KO6
			<u>1</u>	<u>2</u>	<u>3</u>	<u>4</u>					
B11	3 ¹ / ₄ " (82.5)	1 ⁵ / ₈ " (41.3)	12 Ga.	.105	–	–	<u>1</u>	<u>1</u>	<u>1</u>	–	<u>1</u>
B12	2 ⁷ / ₁₆ " (61.9)	1 ⁵ / ₈ " (41.3)	12 Ga.	.105	–	–	<u>1</u> <u>2</u>	<u>1</u>	<u>1</u> <u>2</u>	–	<u>1</u> <u>2</u>
B22	1 ⁵ / ₈ " (41.3)	1 ⁵ / ₈ " (41.3)	12 Ga.	.105	12 Ga.	12 Ga.	<u>1</u> <u>2</u> <u>3</u> <u>4</u>	<u>1</u> <u>3</u>	<u>1</u> <u>2</u> <u>3</u> <u>4</u>	<u>1</u>	<u>1</u> <u>2</u>
B24	1 ⁵ / ₈ " (41.3)	1 ⁵ / ₈ " (41.3)	14 Ga.	–	14 Ga.	14 Ga.	<u>1</u> <u>2</u> <u>3</u> <u>4</u>	<u>1</u>	<u>1</u> <u>2</u> <u>3</u> <u>4</u>	–	<u>1</u> <u>2</u>
B32	1 ³ / ₈ " (34.9)	1 ⁵ / ₈ " (41.3)	12 Ga.	–	12 Ga.	–	<u>1</u> <u>3</u>	<u>1</u>	<u>1</u> <u>3</u>	–	<u>1</u>
B42	1" (25.4)	1 ⁵ / ₈ " (41.3)	12 Ga.	–	12 Ga.	–	<u>1</u> <u>3</u>	<u>1</u>	<u>1</u> <u>3</u>	–	<u>1</u>
B52	1 ³ / ₁₆ " (20.6)	1 ⁵ / ₈ " (41.3)	12 Ga.	–	12 Ga.	12 Ga.	<u>1</u> <u>3</u> <u>4</u>	<u>1</u>	<u>1</u>	–	<u>1</u>
B54	1 ³ / ₁₆ " (20.6)	1 ⁵ / ₈ " (41.3)	14 Ga.	.080	14 Ga.	14 Ga.	<u>1</u> <u>2</u> <u>3</u> <u>4</u>	<u>1</u>	<u>1</u> <u>2</u> <u>3</u> <u>4</u>	–	<u>1</u> <u>2</u>
B62	1 ³ / ₁₆ " (20.6)	1 ³ / ₁₆ " (20.6)	18 Ga.	–	–	–	–	–	–	–	–
B72	1 ³ / ₃₂ " (10.3)	1 ³ / ₁₆ " (20.6)	18 Ga.	–	–	–	–	–	–	–	–

The selection has been prepared to provide a reference for available channel, materials and hole patterns. Material types available for various hole patterns are defined by numbers 1 thru 4.

Some stainless steel channels with hole patterns are available on special order only.

* Metric equivalent for thicknesses shown in chart. ** 1 - Steel
 12 Ga. = 2.6 mm 18 Ga. = 1.2 mm 2 - Aluminum
 14 Ga. = 1.9 mm .105 = 2.6 mm 3 - Type 304 Stainless Steel
 16 Ga. = 1.5 mm .080 = 2.0 mm 4 - Type 316 Stainless Steel

Properties may vary due to commercial tolerances of the material.

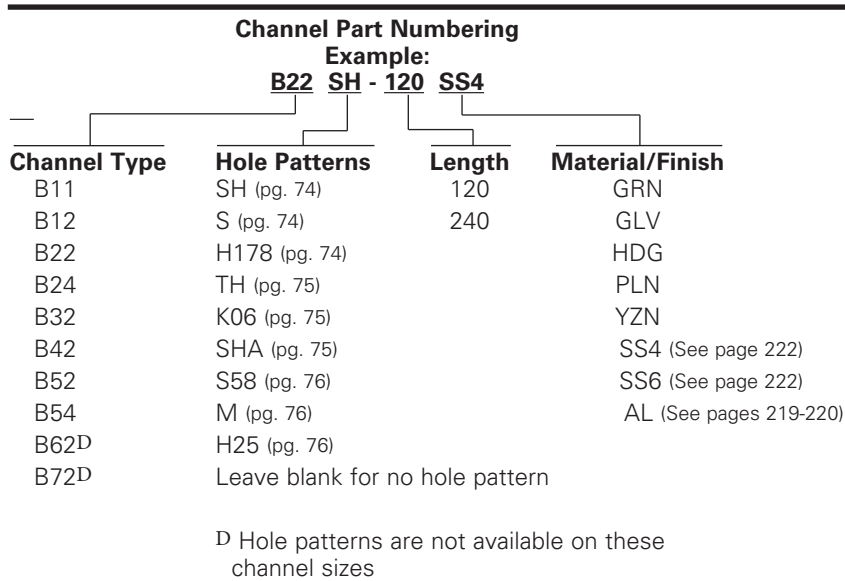

Reference page 48 for general fitting and standard finish specifications.

B11 Channel, combinations & load data

B11

- Thickness: 12 Gauge (2.6 mm)
- Standard lengths: 10' (3.05 m) & 20' (6.09 m)
- Standard finishes: Plain, DURA GREEN™, Pre-Galvanized, Hot-Dipped Galvanized, Aluminum
- Weight: 3.05 Lbs./Ft. (4.54 kg/m)

Note:

Aluminum loading, for B11, can be determined by multiplying load data times a factor of 0.38

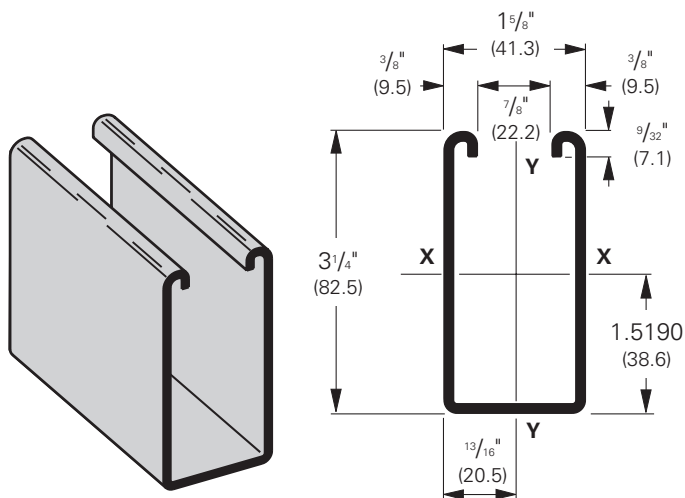

Section Properties			X - X Axis			Y - Y Axis		
Channel	Weight lbs./ft. kg/m	Areas of Section sq. in. cm ²	Moment of Inertia (I) in. ⁴ cm ⁴	Section Modulus (S) in. ³ cm ³	Radius of Gyration (r) in. cm	Moment of Inertia (I) in. ⁴ cm ⁴	Section Modulus (S) in. ³ cm ³	Radius of Gyration (r) in. cm
B11	3.059 (4.55)	.900 (5.81)	1.1203(46.63)	.6472 (10.61)	1.116 (2.83)	.4357(18.14)	.5362 (8.79)	.696 (1.77)
B11A	6.119 (9.11)	1.800(11.61)	6.3931(266.10)	1.9671(32.24)	1.885 (4.79)	.8714(36.27)	1.0725(17.58)	.696 (1.77)

Calculations of section properties are based on metal thicknesses as determined by the AISI Cold-Formed Steel Design Manual.

Beam Loading

Beam Span In. mm	Channel Style	Uniform Load and Deflection				Uniform Load @ Deflection =			
		Lbs.	kN	In.	mm	1/240 Span		1/360 Span	
						Lbs.	kN	Lbs.	kN
24 (609)	B11	5130	(22.82)	.029	(.73)	5130	(22.82)	5130	(22.82)
	B11A	5130*	(22.82)	.005	(.13)	5130*	(22.82)	5130*	(22.82)
36 (914)	B11	3488	(15.51)	.065	(1.65)	3488	(15.51)	3488	(15.51)
	B11A	5130*	(22.82)	.017	(.43)	5130*	(22.82)	5130*	(22.82)
48 (1219)	B11	2616	(11.63)	.117	(2.97)	2616	(11.63)	2616	(11.63)
	B11A	5130*	(22.82)	.040	(1.01)	5130*	(22.82)	5130*	(22.82)
60 (1524)	B11	2093	(9.31)	.183	(4.65)	2093	(9.31)	1908	(8.49)
	B11A	5130*	(22.82)	.079	(2.00)	5130*	(22.82)	5130*	(22.82)
72 (1829)	B11	1744	(7.76)	.263	(6.68)	1744	(7.76)	1325	(5.89)
	B11A	5130*	(22.82)	.136	(3.45)	5130*	(22.82)	5130*	(22.82)
84 (2133)	B11	1495	(6.65)	.358	(9.09)	1460	(6.49)	974	(4.33)
	B11A	4552	(20.25)	.191	(4.85)	4552	(20.25)	4552	(20.25)
96 (2438)	B11	1308	(5.82)	.468	(11.89)	1118	(4.97)	745	(3.31)
	B11A	3983	(17.72)	.250	(6.35)	3983	(17.72)	3983	(17.72)
108 (2743)	B11	1163	(5.17)	.592	(15.03)	884	(3.93)	589	(2.62)
	B11A	3541	(15.75)	.317	(8.05)	3541	(15.75)	3353	(14.91)
120 (3048)	B11	1046	(4.65)	.731	(18.57)	716	(3.18)	477	(2.12)
	B11A	3187	(14.17)	.391	(9.93)	3187	(14.17)	2716	(12.08)
144 (3657)	B11	872	(3.88)	1.053	(26.74)	497	(2.21)	331	(1.47)
	B11A	2656	(11.81)	.563	(14.30)	2656	(11.81)	1886	(8.39)
168 (4267)	B11	747	(3.32)	1.433	(36.40)	365	(1.62)	243	(1.08)
	B11A	2276	(10.12)	.766	(19.45)	2078	(9.24)	1386	(6.16)
192 (4877)	B11	654	(2.91)	1.871	(47.52)	280	(1.24)	186	(0.83)
	B11A	1992	(8.86)	1.001	(25.42)	1591	(7.08)	1061	(4.72)
216 (5486)	B11	581	(2.58)	2.368	(60.15)	221	(0.98)	147	(0.65)
	B11A	1770	(7.87)	1.267	(32.18)	1257	(5.59)	838	(3.73)
240 (6096)	B11	523	(2.32)	2.924	(74.27)	179	(0.79)	119	(0.53)
	B11A	1593	(7.08)	1.564	(39.72)	1018	(4.53)	679	(3.02)

Based on simple beam condition using an allowable design stress of 25,000 psi (172 MPa) in accordance with MFMA, with adequate lateral bracing (see page 12 for further explanation). Actual yield point of cold rolled steel is 42,000 psi (289 MPa). To determine concentrated load capacity at mid span, multiply uniform load by 0.5 and corresponding deflection by 0.8. *Failure determined by weld shear.

Reference page 48 for general fitting and standard finish specifications.

B11 Beam & column loading data

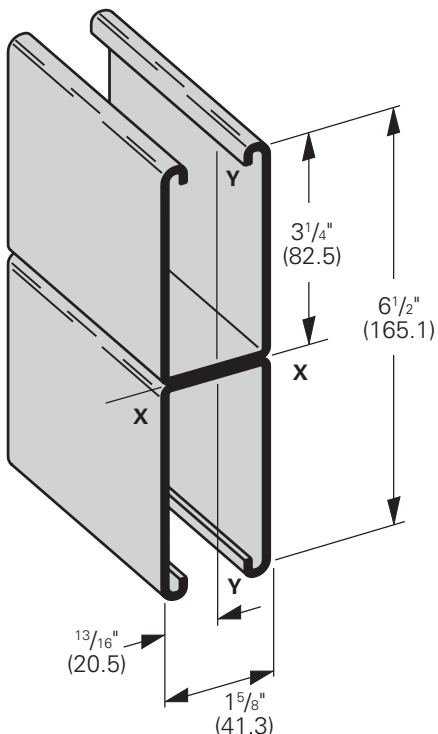

B11A
Wt. 6.10 Lbs./Ft. (9.08 kg/m)

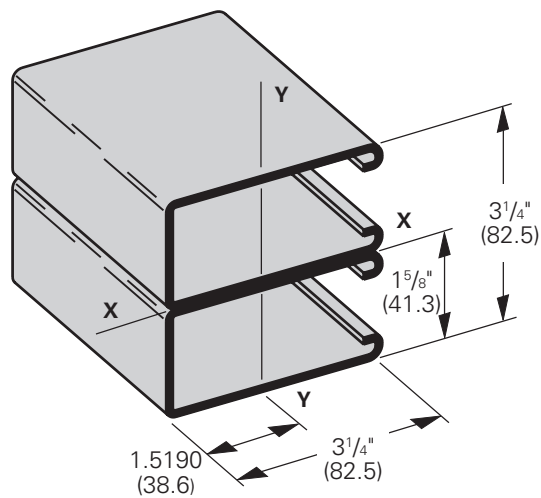

B11B
Wt. 6.10 Lbs./Ft. (9.08 kg/m)

Column Loading

Unbraced Height In. mm	Channel Style	Max. Column Loading K = .80				Max. Column Loading (Loaded @ C.G.)					
		Loaded@ C.G.		Loaded@ Slot Face		K = .65		K = 1.0		K = 1.2	
		Lbs.	kN	Lbs.	kN	Lbs.	kN	Lbs.	kN	Lbs.	kN
24 (609)	B11	8190	(36.43)	4477	(19.91)	8446	(37.57)	7783	(34.62)	7311	(32.52)
	B11A	17701	(78.74)	8267	(36.77)	17778	(79.08)	17572	(78.16)	17416	(77.47)
36 (914)	B11	7311	(32.52)	4183	(18.61)	7838	(34.86)	6503	(28.93)	5612	(24.96)
	B11A	17416	(77.47)	8189	(36.42)	17590	(78.24)	17127	(76.18)	16774	(74.61)
48 (1219)	B11	6214	(27.64)	3783	(16.83)	7053	(31.37)	4988	(22.19)	3816	(16.97)
	B11A	17016	(75.69)	8079	(35.94)	17327	(77.07)	16503	(73.41)	15876	(70.62)
60 (1524)	B11	4988	(22.19)	3279	(14.58)	6140	(27.31)	3595	(15.99)	2790	(12.41)
	B11A	16503	(73.41)	7727	(34.37)	16988	(75.56)	15701	(69.84)	14721	(65.48)
72 (1829)	B11	3816	(16.97)	2444	(10.87)	5146	(22.89)	2790	(12.41)	2213	(9.84)
	B11A	15876	(70.62)	6160	(27.40)	16574	(73.72)	14721	(65.48)	13310	(59.20)
84 (2133)	B11	3063	(13.62)	1897	(8.44)	4133	(18.38)	2291	(10.19)	1846	(8.21)
	B11A	15135	(67.32)	4961	(22.07)	16084	(71.54)	13563	(60.33)	11642	(51.78)
96 (2438)	B11	2564	(11.40)	1532	(6.81)	3398	(15.11)	1953	(8.69)	1591	(7.08)
	B11A	14279	(63.51)	4045	(17.99)	15520	(69.03)	12226	(54.38)	9717	(43.22)
108 (2743)	B11	2213	(9.84)	1273	(5.66)	2886	(12.84)	1708	(7.60)	1401	(6.23)
	B11A	13310	(59.20)	3337	(14.84)	14880	(66.19)	10712	(47.65)	7725	(34.36)
120 (3048)	B11	1953	(8.69)	1081	(4.81)	2514	(11.18)	1522	(6.77)	1251**	(5.56)
	B11A	12226	(54.38)	2784	(12.38)	14164	(63.00)	9019	(40.12)	6257**	(27.83)
144 (3657)	B11	1591	(7.08)	816	(3.63)	2011	(8.94)	1251**	(5.56)	1026**	(4.56)
	B11A	9717	(43.22)	1990	(8.85)	12508	(55.64)	6257**	(27.83)	4345**	(19.33)
168 (4267)	B11	1347	(5.99)	642	(2.85)	1687	(7.50)	1058**	(4.70)	859**	(3.82)
	B11A	7183	(31.95)	1464	(6.51)	10550	(46.93)	4597**	(20.45)	3192**	(14.20)
192 (4877)	B11	1167**	(5.19)	519	(2.31)	1459	(6.49)	910**	(4.05)	-	-
	B11A	5499**	(24.46)	1121	(4.98)	8330	(37.05)	3520**	(15.66)	-	-
216 (5486)	B11	1026**	(4.56)	429	(1.91)	1285**	(5.71)	-	-	-	-
	B11A	4345**	(19.33)	885	(3.93)	6582**	(29.28)	-	-	-	-
40 (6096)	B11	910**	(4.05)	360	(1.60)	1148**	(5.10)	-	-	-	-
	B11A	3520**	(15.66)	717	(3.19)	5331**	(23.71)	-	-	-	-

**Where the slenderness ratio $\frac{KL}{r}$ exceeds 200, and K = end fixity factor, L = actual length and r = radius of gyration.

Reference page 48 for general fitting and standard finish specifications.

B12 Channel, combinations

B12

- Thickness: 12 Gauge (2.6 mm)
- Standard lengths: 10' (3.05 m) & 20' (6.09 m)
- Standard finishes: Plain, DURA GREEN™, Pre-Galvanized, Hot-Dipped Galvanized, Aluminum
- Weight: 2.47 Lbs./Ft. (3.67 kg/m)

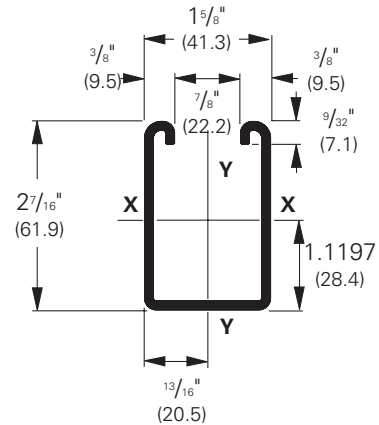
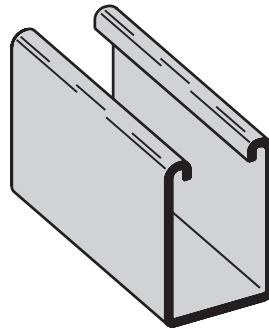

Note:

Aluminum loading, for B12, can be determined by multiplying load data times a factor of 0.38

Section Properties			X - X Axis			Y - Y Axis		
Channel	Weight lbs./ft. kg/m	Areas of Section sq. in. cm ²	Moment of Inertia (I) in. ⁴ cm ⁴	Section Modulus (S) in. ³ cm ³	Radius of Gyration (r) in. cm	Moment of Inertia (I) in. ⁴ cm ⁴	Section Modulus (S) in. ³ cm ³	Radius of Gyration (r) in. cm
B12	2.484 (3.70)	.731 (4.71)	.5349 (22.26)	.4061 (6.65)	.856 (2.17)	.3377 (14.06)	.4156 (6.81)	.680 (1.73)
B12A	4.969 (7.40)	1.462 (9.43)	2.9036 (120.86)	1.1915 (19.52)	1.409 (3.58)	.6756 (28.12)	.8315 (13.63)	.680 (1.73)

Calculations of section properties are based on metal thicknesses as determined by the AISI Cold-Formed Steel Design Manual.

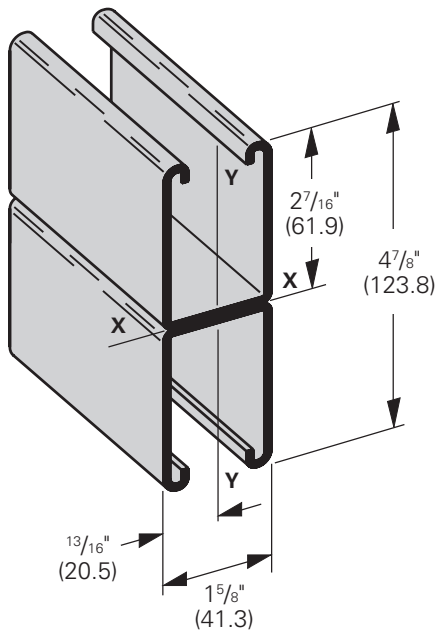

B12A
Wt. 4.94 Lbs./Ft. (7.35 kg/m)

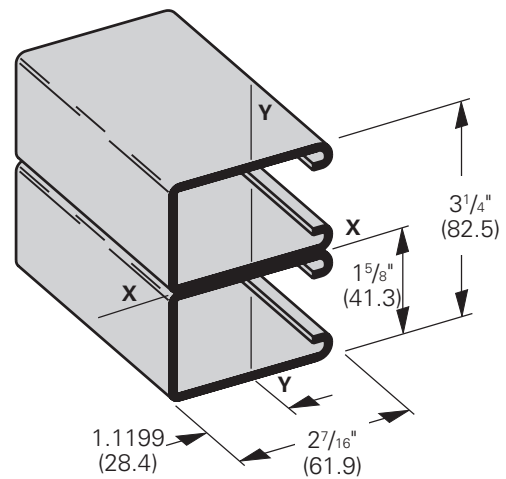

B12B
Wt. 4.94 Lbs./Ft. (7.35 kg/m)

B12 Beam & column loading data

Beam Loading

Beam Span In. mm	Channel Style	Uniform Load and Deflection				Uniform Load @ Deflection =			
		Lbs.		kN		1/240 Span		1/360 Span	
		In.	mm	Lbs.	kN	Lbs.	kN	Lbs.	kN
12 (305)	B12	3880	(17.26)	.009	(.23)	3880	(17.26)	3880	(17.26)
	B12A	3880*	(17.26)	.001	(.02)	3880*	(17.26)	3880*	(17.26)
24 (609)	B12	3273	(14.56)	.038	(.96)	3273	(14.56)	3273	(14.56)
	B12A	3880*	(17.26)	.008	(.20)	3880*	(17.26)	3880*	(17.26)
36 (914)	B12	2182	(9.70)	.086	(2.18)	2182	(9.70)	2182	(9.70)
	B12A	3880*	(17.26)	.028	(.71)	3880*	(17.26)	3880*	(17.26)
48 (1219)	B12	1636	(7.28)	.153	(3.88)	1636	(7.28)	1421	(6.32)
	B12A	3880*	(17.26)	.067	(1.70)	3880*	(17.26)	3880*	(17.26)
60 (1524)	B12	1309	(5.82)	.240	(6.09)	1309	(5.82)	909	(4.04)
	B12A	3847*	(17.11)	.130	(3.30)	3847*	(17.11)	3847*	(17.11)
72 (1829)	B12	1091	(4.85)	.345	(8.76)	947	(4.21)	632	(2.81)
	B12A	3206	(14.26)	.188	(4.77)	3206	(14.26)	3206	(14.26)
84 (2133)	B12	935	(4.16)	.470	(11.94)	696	(3.09)	464	(2.06)
	B12A	2748	(12.22)	.255	(6.48)	2748	(12.22)	2509	(11.16)
96 (2438)	B12	818	(3.64)	.614	(15.59)	533	(2.37)	355	(1.58)
	B12A	2404	(10.69)	.334	(8.48)	2404	(10.69)	1921	(8.54)
108 (2743)	B12	727	(3.23)	.777	(19.73)	421	(1.87)	281	(1.25)
	B12A	2137	(9.50)	.422	(10.72)	2137	(9.50)	1518	(6.75)
120 (3048)	B12	655	(2.93)	.959	(24.36)	341	(1.52)	227	(1.01)
	B12A	1924	(8.56)	.521	(13.23)	1844	(8.20)	1229	(5.47)

Based on simple beam condition using an allowable design stress of 25,000 psi (172 MPa) in accordance with MFMA, with adequate lateral bracing (see page 12 for further explanation). Actual yield point of cold rolled steel is 42,000 psi. To determine concentrated load capacity at mid span, multiply uniform load by 0.5 and corresponding deflection by 0.8. *Failure determined by weld shear.

Column Loading

Unbraced Height In. mm	Channel Style	Max. Column Loading K = .80				Max. Column Loading (Loaded @ C.G.)					
		Loaded@ C.G.		Loaded@ Slot Face		K = .65		K = 1.0		K = 1.2	
		Lbs.	kN	Lbs.	kN	Lbs.	kN	Lbs.	kN	Lbs.	kN
12 (305)	B12	10140	(45.10)	4752	(21.14)	10247	(45.58)	9965	(44.32)	9756	(43.40)
	B12A	20820	(92.61)	8023	(35.69)	20854	(92.76)	20763	(92.36)	20694	(92.05)
24 (609)	B12	9244	(41.12)	4514	(20.08)	9639	(42.87)	8629	(38.38)	7933	(35.29)
	B12A	20519	(91.27)	7956	(35.39)	20655	(91.88)	20293	(90.27)	20017	(89.04)
36 (914)	B12	7933	(35.29)	4137	(18.40)	8711	(35.75)	6786	(30.18)	5572	(24.78)
	B12A	20017	(89.04)	7844	(34.89)	20324	(90.40)	19509	(86.78)	18889	(84.02)
48 (1219)	B12	6386	(28.40)	3638	(16.18)	7562	(33.64)	4785	(21.28)	3717	(16.53)
	B12A	19315	(85.92)	7688	(34.20)	19861	(88.34)	18412	(81.90)	17309	(76.99)
60 (1524)	B12	4785	(21.28)	2963	(13.18)	6285	(27.96)	3523	(15.67)	2806	(12.48)
	B12A	18412	(81.90)	6941	(30.87)	19265	(85.69)	17002	(75.63)	15278	(67.96)
72 (1829)	B12	3717	(16.53)	2197	(9.77)	4964	(22.08)	2806	(12.48)	2271	(10.10)
	B12A	17309	(76.99)	5334	(23.73)	18536	(82.45)	15278	(67.96)	12795	(56.91)
84 (2133)	B12	3052	(13.57)	1717	(7.64)	3994	(17.76)	2345	(10.43)	1913	(8.51)
	B12A	16005	(71.19)	4176	(18.57)	17675	(78.62)	13240	(58.89)	9884	(43.96)
96 (2438)	B12	2600	(11.56)	1391	(6.19)	3350	(14.90)	2019	(8.98)	1650	(7.34)
	B12A	14500	(64.50)	3328	(14.80)	16682	(74.20)	10889	(48.43)	7567	(33.66)
108 (2743)	B12	2271	(10.10)	1155	(5.14)	2893	(12.87)	1773	(7.88)	1446	(6.43)
	B12A	12795	(56.91)	2692	(11.97)	15556	(69.19)	8610	(38.30)	5979	(26.59)
120 (3048)	B12	2019	(8.98)	977	(4.34)	2553	(11.35)	1577	(7.01)	1279**	(5.69)
	B12A	10889	(48.43)	2202	(9.79)	14298	(63.60)	6974	(31.02)	4843**	(21.54)

**Where the slenderness ratio $\frac{L}{r}$ exceeds 200, and K = end fixity factor, L = actual length and r = radius of gyration.

Reference page 48 for general fitting and standard finish specifications.

B22 Channel

B22

- Thickness: 12 Gauge (2.6 mm)
- Standard lengths: 10' (3.05 m) & 20' (6.09 m)
- Standard finishes: Plain, DURA GREEN™, Pre-Galvanized, Hot-Dipped Galvanized, Stainless Steel Type 304 or 316, Aluminum
- Weight: 1.90 Lbs./Ft. (2.83 kg/m)

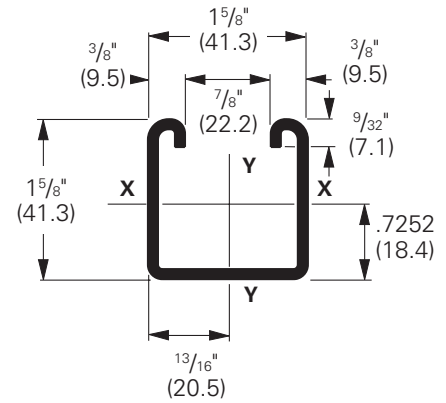
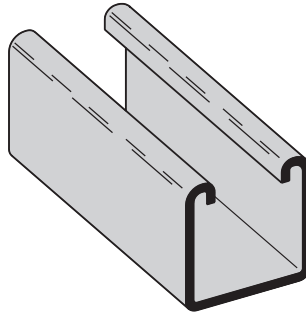

Note:

Aluminum loading, for B22 & B22A, can be determined by multiplying load data times a factor of 0.38

Section Properties			X - X Axis				Y - Y Axis				
Channel	Weight lbs./ft. kg/m	Areas of Section sq. in. cm ²	Moment of Inertia (I) in. ⁴ cm ⁴	Section Modulus (S) in. ³ cm ³	Radius of Gyration (r) in. cm	Moment of Inertia (I) in. ⁴ cm ⁴	Section Modulus (S) in. ³ cm ³	Radius of Gyration (r) in. cm			
B22	1.910 (2.84)	.562 (3.62)	.1912 (7.96)	.2125 (3.48)	.583 (1.48)	.2399 (9.99)	.2953 (4.84)	.653 (1.66)			
B22A	3.820 (5.69)	1.124 (7.25)	.9732 (40.51)	.5989 (9.81)	.931 (2.36)	.4798 (19.97)	.5905 (9.68)	.653 (1.66)			
B22X	6.649 (9.89)	1.956 (12.62)	4.1484 (172.67)	1.7019 (27.89)	1.456 (3.70)	1.1023 (45.88)	1.2027 (19.71)	.751 (1.91)			

Calculations of section properties are based on metal thicknesses as determined by the AISI Cold-Formed Steel Design Manual.

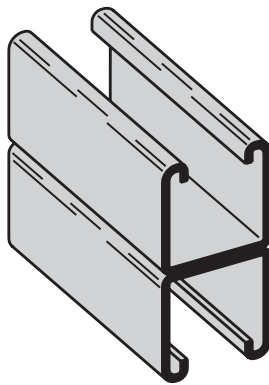

B22A

Wt. 3.80 Lbs./Ft. (5.65 kg/m)

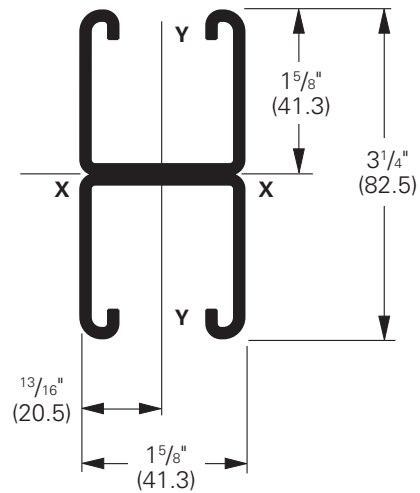

B22 Combinations

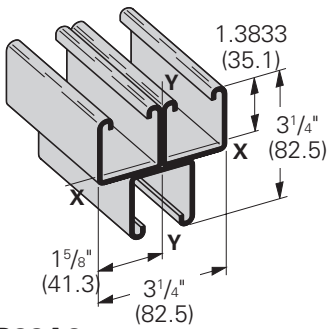

B22A3

Wt. 5.70 Lbs./Ft. (8.48 kg/m)

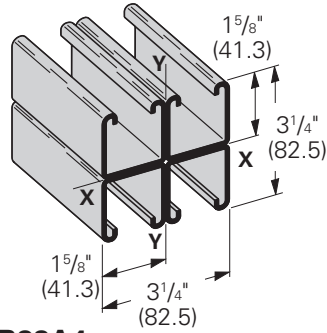

B22A4

Wt. 7.60 Lbs./Ft. (11.31 kg/m)

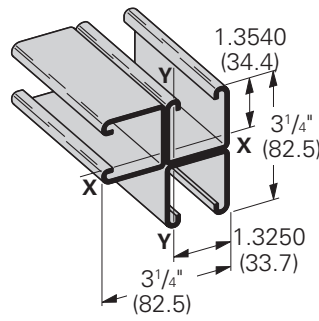

B22AD3

Wt. 5.70 Lbs./Ft. (8.48 kg/m)

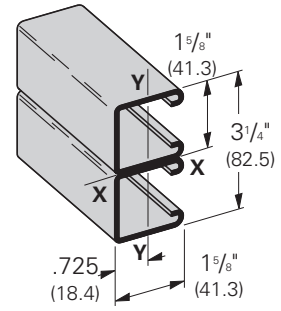

B22B

Wt. 3.80 Lbs./Ft. (5.65 kg/m)

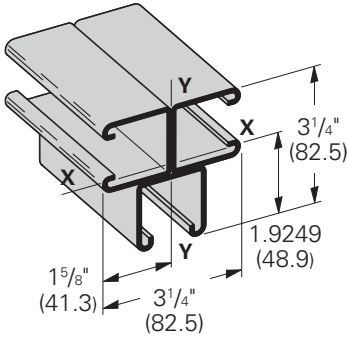

B22B3

Wt. 5.70 Lbs./Ft. (8.48 kg/m)

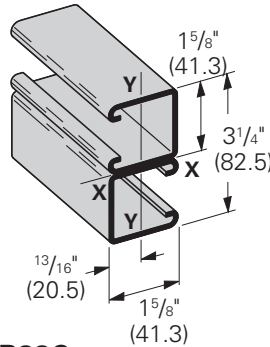

B22C

Wt. 3.80 Lbs./Ft. (5.65 kg/m)

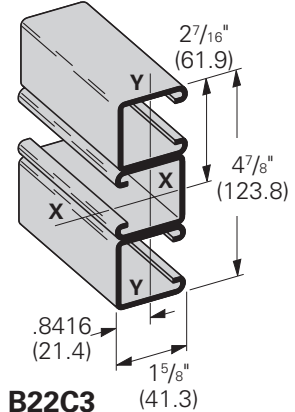

B22C3

Wt. 5.70 Lbs./Ft. (8.48 kg/m)

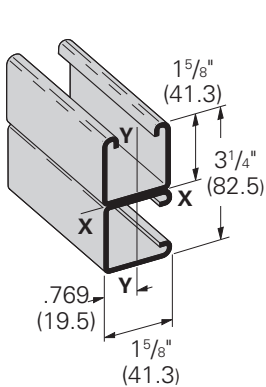

B22D

Wt. 3.80 Lbs./Ft. (5.65 kg/m)

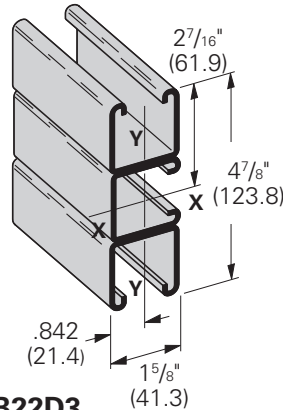

B22D3

Wt. 5.70 Lbs./Ft. (8.48 kg/m)

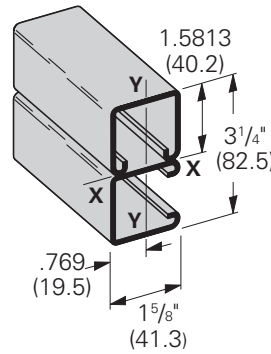

B22E

Wt. 3.80 Lbs./Ft. (5.65 kg/m)

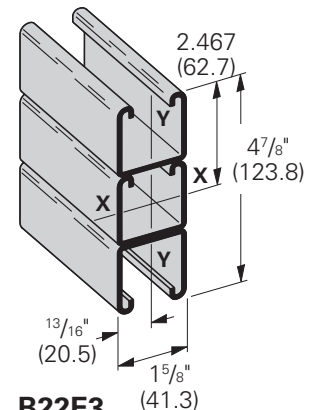

B22E3

Wt. 5.70 Lbs./Ft. (8.48 kg/m)

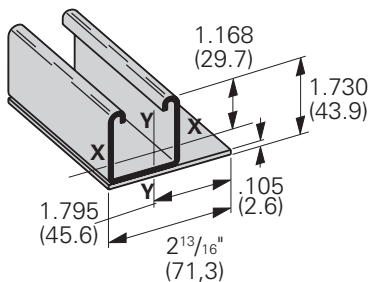

B22LPL

Wt. 2.90 Lbs./Ft. (4.31 kg/m)

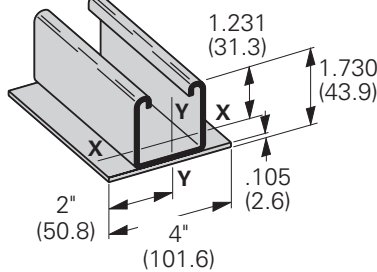

B22PL

Wt. 3.35 Lbs./Ft. (4.98 kg/m)

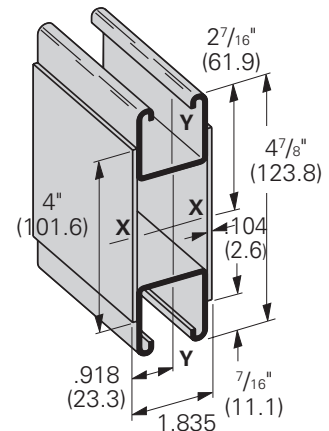

B22X

Wt. 6.70 Lbs./Ft. (9.97 kg/m)

Reference page 48 for general fitting and standard finish specifications.

Channel & Combinations

B22 Beam loading data

Beam Loading

Beam Span In. mm	Channel Style	Uniform Load and Deflection				Uniform Load @ Deflection =			
		Lbs.	kN	In.	mm	1/240 Span Lbs.	kN	1/360 Span Lbs.	kN
12 (305)	B22	2610	(11.61)	.014	(.35)	2610	(11.61)	2610	(11.61)
	B22A	2610*	(11.61)	.002	(.05)	2610*	(11.61)	2610*	(11.61)
	B22X	5790*	(25.75)	.001	(.02)	5790*	(25.75)	5790*	(25.75)
18 (457)	B22	2269	(10.09)	.031	(.79)	2269	(10.09)	2269	(10.09)
	B22A	2610*	(11.61)	.007	(.18)	2610*	(11.61)	2610*	(11.61)
	B22X	5790*	(25.75)	.003	(.07)	5790*	(25.75)	5790*	(25.75)
24 (609)	B22	1702	(7.57)	.056	(1.42)	1702	(7.57)	1702	(7.57)
	B22A	2610*	(11.61)	.017	(.43)	2610*	(11.61)	2610*	(11.61)
	B22X	5790*	(25.75)	.008	(.20)	5790*	(25.75)	5790*	(25.75)
30 (762)	B22	1361	(6.05)	.087	(2.21)	1361	(6.05)	1294	(5.75)
	B22A	2610*	(11.61)	.033	(.84)	2610*	(11.61)	2610*	(11.61)
	B22X	5790*	(25.75)	.017	(.73)	5790*	(25.75)	5790*	(25.75)
36 (914)	B22	1135	(5.05)	.126	(3.20)	1135	(5.05)	899	(4.00)
	B22A	2610*	(11.61)	.057	(1.45)	2610*	(11.61)	2610*	(11.61)
	B22X	5790*	(25.75)	.029	(.73)	5790*	(25.75)	5790*	(25.75)
42 (1067)	B22	972	(4.32)	.172	(4.37)	972	(4.32)	660	(2.93)
	B22A	2610*	(11.61)	.091	(2.31)	2610*	(11.61)	2610*	(11.61)
	B22X	5790*	(25.75)	.046	(1.17)	5790*	(25.75)	5790*	(25.75)
48 (1219)	B22	851	(3.78)	.224	(5.69)	758	(3.37)	505	(2.24)
	B22A	2405	(10.70)	.125	(3.17)	2405	(10.70)	2405	(10.70)
	B22X	5790*	(25.75)	.068	(1.73)	5790*	(25.75)	5790*	(25.75)
54 (1371)	B22	756	(3.36)	.284	(7.21)	599	(2.66)	399	(1.77)
	B22A	2138	(9.51)	.158	(4.01)	2138	(9.51)	2024	(9.00)
	B22X	5790*	(25.75)	.097	(2.46)	5790*	(25.75)	5790*	(25.75)
60 (1524)	B22	681	(3.03)	.351	(8.91)	485	(2.16)	323	(1.44)
	B22A	1924	(8.56)	.195	(4.95)	1924	(8.56)	1640	(7.29)
	B22X	5645	(25.11)	.130	(3.30)	5645	(25.11)	5645	(25.11)
66 (1676)	B22	619	(2.75)	.424	(10.77)	401	(1.78)	267	(1.19)
	B22A	1749	(7.78)	.236	(5.99)	1749	(7.78)	1355	(6.03)
	B22X	5132	(22.83)	.158	(4.01)	5132	(22.83)	5132	(22.83)
72 (1829)	B22	567	(2.52)	.505	(12.83)	337	(1.50)	225	(1.00)
	B22A	1603	(7.13)	.281	(7.14)	1603	(7.13)	1139	(5.06)
	B22X	4704	(20.92)	.188	(4.77)	4704	(20.92)	4704	(20.92)
78 (1981)	B22	524	(2.33)	.593	(15.06)	287	(1.27)	191	(0.85)
	B22A	1480	(6.58)	.330	(8.38)	1455	(6.47)	970	(4.31)
	B22X	4342	(19.31)	.220	(5.59)	4342	(19.31)	4270	(18.99)
84 (2133)	B22	486	(2.16)	.687	(17.45)	248	(1.10)	165	(0.73)
	B22A	1374	(6.11)	.383	(9.73)	1255	(5.58)	837	(3.72)
	B22X	4032	(17.93)	.255	(6.48)	4032	(17.93)	3682	(16.38)
90 (2286)	B22	454	(2.02)	.789	(20.04)	216	(0.96)	144	(0.64)
	B22A	1283	(5.71)	.440	(11.17)	1093	(4.86)	729	(3.24)
	B22X	3763	(16.74)	.293	(7.44)	3763	(16.74)	3207	(14.26)
96 (2438)	B22	425	(1.89)	.898	(22.81)	190	(0.84)	126	(0.56)
	B22A	1202	(5.35)	.500	(12.70)	961	(4.27)	640	(2.85)
	B22X	3528	(15.69)	.334	(8.48)	3528	(15.69)	2819	(12.54)
102 (2591)	B22	400	(1.78)	1.013	(25.73)	168	(0.75)	112	(0.50)
	B22A	1132	(5.03)	.565	(14.35)	851	(3.78)	567	(2.52)
	B22X	3320	(14.77)	.377	(9.57)	3320	(14.77)	2497	(11.11)
108 (2743)	B22	378	(1.68)	1.136	(28.85)	150	(0.67)	100	(0.44)
	B22A	1069	(4.75)	.633	(16.08)	759	(3.37)	506	(2.25)
	B22X	3136	(13.95)	.422	(10.72)	3136	(13.95)	2227	(9.90)
114 (2895)	B22	358	(1.59)	1.266	(32.15)	134	(0.59)	90	(0.40)
	B22A	1013	(4.50)	.706	(17.93)	681	(3.03)	454	(2.02)
	B22X	2971	(13.21)	.471	(11.96)	2971	(13.21)	1999	(8.89)
120 (3048)	B22	340	(1.51)	1.403	(35.63)	121	(0.54)	81	(0.36)
	B22A	962	(4.28)	.782	(19.86)	615	(2.73)	410	(1.82)
	B22X	2822	(12.55)	.521	(13.23)	2706	(12.04)	1804	(8.02)

Based on simple beam condition using an allowable design stress of 25,000 psi (172 MPa) in accordance with MFMA, with adequate lateral bracing (see page 12 for further explanation). Actual yield point of cold rolled steel is 42,000 psi. To determine concentrated load capacity at mid span, multiply uniform load by 0.5 and corresponding deflection by 0.8. *Failure determined by weld shear.

Reference page 48 for general fitting and standard finish specifications.

Column Loading

Unbraced Height		Channel Style	Max. Column Loading K = .80				Max. Column Loading (Loaded @ C.G.)					
			Loaded @ C.G.		Loaded @ Slot Face		K = .65		K = 1.0		K = 1.2	
			In.	mm	Lbs.	kN	Lbs.	kN	Lbs.	kN	Lbs.	kN
12	(305)	B22	10454	(46.50)	4276	(19.12)	10598	(47.14)	10222	(45.47)	9950	(44.26)
		B22A	21625	(96.19)	7002	(31.14)	21677	(96.42)	21539	(95.81)	21433	(95.34)
		B22X	46948	(208.83)	18975	(84.40)	47061	(209.34)	46761	(208.00)	46531	(206.98)
18	(457)	B22	9950	(44.26)	4153	(18.47)	10253	(45.62)	9481	(42.17)	8955	(39.83)
		B22A	21433	(95.34)	6959	(30.95)	21551	(95.86)	21239	(94.47)	21001	(93.42)
		B22X	46531	(206.98)	18859	(83.90)	46787	(208.12)	46110	(205.11)	45593	(202.81)
24	(609)	B22	9311	(41.42)	3993	(17.76)	9801	(43.60)	8582	(38.17)	7801	(34.70)
		B22A	21164	(94.14)	6898	(30.68)	21373	(95.07)	20819	(92.61)	20397	(90.73)
		B22X	45947	(204.38)	18693	(84.44)	46401	(206.40)	45198	(201.05)	44282	(196.97)
30	(762)	B22	8582	(38.17)	3802	(16.91)	9268	(41.22)	7601	(33.81)	6595	(29.33)
		B22A	20819	(92.61)	6821	(30.34)	21145	(94.06)	20279	(90.20)	19619	(87.27)
		B22X	45198	(201.05)	18485	(82.22)	45906	(204.20)	44026	(195.84)	42593	(189.46)
36	(914)	B22	7801	(34.70)	3589	(15.96)	8676	(38.59)	6595	(28.33)	5392	(23.98)
		B22A	20397	(90.73)	6728	(29.93)	20866	(92.81)	19619	(87.27)	18669	(83.04)
		B22X	44282	(196.97)	18233	(81.10)	45300	(201.50)	42593	(189.46)	40530	(180.28)
42	(1067)	B22	6998	(31.13)	3360	(14.94)	8048	(35.80)	5595	(24.89)	4444	(19.77)
		B22A	19898	(88.51)	6620	(29.45)	20537	(91.33)	18840	(83.80)	17546	(78.05)
		B22X	43198	(192.15)	17940	(79.80)	44586	(198.33)	40901	(181.94)	38092	(169.44)
48	(1219)	B22	6193	(27.55)	3118	(13.87)	7401	(32.92)	4718	(20.99)	3791	(16.86)
		B22A	19322	(85.95)	6496	(28.89)	20157	(89.66)	17940	(79.80)	16251	(72.29)
		B22X	41948	(186.59)	17604	(78.30)	43761	(194.57)	38948	(173.25)	35281	(156.94)
54	(1371)	B22	5392	(23.98)	2864	(12.74)	6746	(30.01)	4090	(18.19)	3310	(14.72)
		B22A	18669	(83.04)	6263	(27.86)	19276	(87.74)	16920	(75.26)	14782	(65.75)
		B22X	40530	(180.28)	16973	(75.50)	42825	(190.49)	36733	(163.39)	32092	(142.75)
60	(1524)	B22	4718	(20.99)	2631	(11.70)	6093	(27.10)	3616	(16.08)	2936	(13.06)
		B22A	17940	(79.80)	5340	(23.75)	19244	(85.60)	15781	(70.20)	13141	(58.45)
		B22X	38948	(173.25)	14471	(64.37)	41779	(185.84)	34260	(152.39)	28529	(126.90)
66	(1676)	B22	4202	(18.69)	2434	(10.83)	5441	(24.20)	3242	(14.42)	2634	(11.71)
		B22A	17134	(76.21)	4587	(20.40)	18712	(83.23)	14521	(64.59)	11328	(50.39)
		B22X	37198	(165.46)	12431	(55.29)	40624	(180.70)	31525	(140.23)	24593	(109.39)
72	(1829)	B22	3791	(16.86)	2264	(10.07)	4869	(21.66)	2936	(13.06)	2381	(10.59)
		B22A	16251	(72.29)	3968	(17.65)	18129	(80.64)	13141	(58.45)	9524	(42.36)
		B22X	35281	(156.94)	10753	(47.83)	39358	(175.07)	28529	(126.90)	20676	(91.97)
78	(1981)	B22	3456	(15.37)	2116	(9.41)	4412	(19.62)	2680	(11.92)	2166	(9.63)
		B22A	15291	(68.02)	3456	(15.37)	17496	(77.82)	11642	(51.78)	8115	(36.10)
		B22X	33197	(147.67)	9366	(41.66)	37984	(168.96)	25275	(112.43)	17617	(78.36)
84	(2133)	B22	3176	(14.13)	1984	(8.82)	4037	(17.96)	2461	(10.95)	1980	(8.81)
		B22A	14255	(63.41)	3028	(13.47)	16812	(74.78)	10076	(44.82)	6998	(31.13)
		B22X	30947	(137.66)	8206	(36.50)	36499	(162.35)	21875	(97.30)	15192	(67.58)
90	(2286)	B22	2936	(13.06)	1867	(8.30)	3724	(16.56)	2270	(10.10)	1816	(8.08)
		B22A	13141	(58.45)	2667	(11.86)	16077	(71.51)	8778	(39.04)	6096	(27.11)
		B22X	28529	(126.90)	7227	(32.15)	34903	(155.25)	19057	(84.77)	13234	(58.87)
96	(2438)	B22	2728	(16.58)	1761	(7.83)	3456	(15.37)	2101	(9.34)	1671	(7.43)
		B22A	11951	(53.16)	2359	(10.49)	15291	(68.02)	7715	(34.32)	5357	(23.83)
		B22X	25945	(115.41)	6393	(28.44)	33197	(147.67)	16749	(74.50)	11630	(51.73)
102	(2591)	B22	2545	(11.32)	1664	(7.40)	3225	(14.34)	1951	(8.68)	1542**	(6.34)
		B22A	10678	(47.50)	2093	(9.31)	14455	(64.30)	6834	(30.40)	4746	(21.11)
		B22X	23182	(103.12)	5672	(25.23)	31382	(139.59)	14836	(65.99)	10303	(45.83)
108	(2743)	B22	2381	(10.59)	1575	(7.00)	3022	(13.44)	1816	(8.08)	1426**	(68.60)
		B22A	9524	(42.36)	1867	(8.30)	13568	(60.35)	6096	(27.11)	4233	(18.83)
		B22X	20676	(91.97)	5059	(22.50)	29456	(131.03)	13234	(58.87)	9190	(40.88)
114	(2895)	B22	2234	(9.94)	1494	(6.64)	2842	(12.64)	1694	(7.53)	1322**	(5.88)
		B22A	8548	(38.02)	1675	(7.45)	12630	(56.18)	5471	(24.33)	3799**	(16.90)
		B22X	18558	(82.55)	4539	(20.19)	27420	(121.97)	11877	(52.83)	8247	(36.68)
120	(3048)	B22	2101	(9.34)	1418	(6.31)	2680	(11.92)	1583**	(7.04)	1228**	(5.46)
		B22A	7715	(34.32)	1512	(6.72)	11642	(51.78)	4937	(21.96)	3429**	(15.25)
		B22X	16749	(74.50)	4097	(18.22)	25275	(112.43)	10718	(47.67)	7444	(33.11)

**Where the slenderness ratio $\frac{KL}{r}$ exceeds 200, and K = end fixity factor, L = actual length and r = radius of gyration.

Reference page 48 for general fitting and standard finish specifications.

B24 Channel & combinations

B24

- Thickness: 14 Gauge (1.9 mm)
- Standard lengths: 10' (3.05 m) & 20' (6.09 m)
- Standard finishes: Plain, DURA GREEN™, Pre-Galvanized, Hot-Dipped Galvanized, Stainless Steel Type 304 or 316
- Weight: 1.40 Lbs./Ft. (2.08 kg/m)

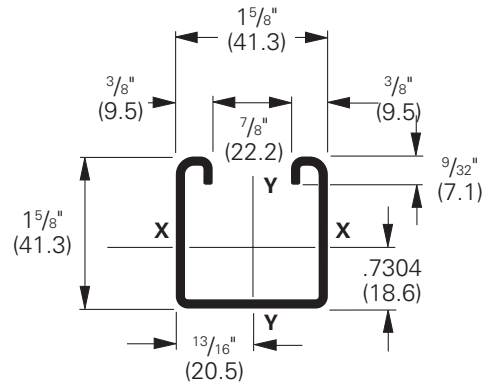
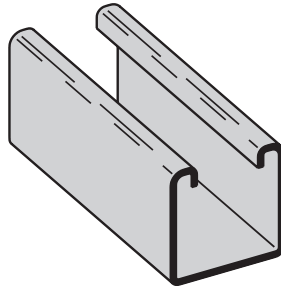

Section Properties			X - X Axis			Y - Y Axis		
Channel	Weight lbs./ft. kg/m	Areas of Section sq. in. cm ²	Moment of Inertia (I) in. ⁴ cm ⁴	Section Modulus (S) in. ³ cm ³	Radius of Gyration (r) in. cm	Moment of Inertia (I) in. ⁴ cm ⁴	Section Modulus (S) in. ³ cm ³	Radius of Gyration (r) in. cm
B24	1.442 (2.15)	.424 (2.74)	.1494 (6.22)	.1670 (2.74)	.594 (1.51)	.1857 (7.73)	.2286 (3.75)	.662 (1.68)
B24A	2.884 (4.29)	.848 (5.47)	.7514 (31.28)	.4624 (7.58)	.941 (2.39)	.3713 (15.45)	.4570 (7.49)	.662 (1.68)

Calculations of section properties are based on metal thicknesses as determined by the AISI Cold-Formed Steel Design Manual.

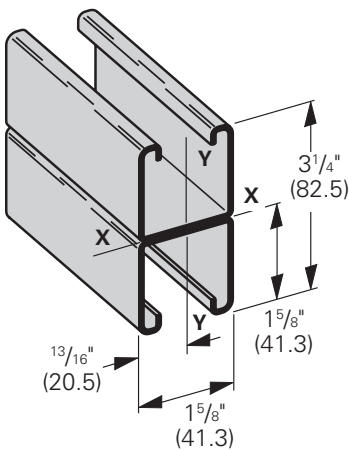

B24A
Wt. 2.80 Lbs./Ft. (4.16 kg/m)

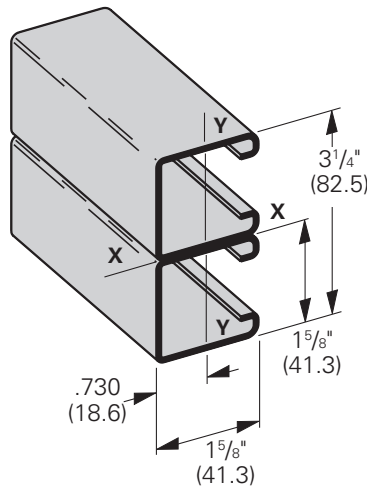

B24B
Wt. 2.80 Lbs./Ft. (4.16 kg/m)

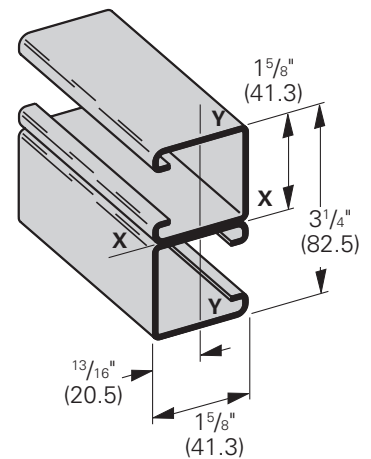

B24C
Wt. 2.80 Lbs./Ft. (4.16 kg/m)

Reference page 48 for general fitting and standard finish specifications.

B24 Beam & column loading data

Beam Loading

Beam Span In. mm		Channel Style	Uniform Load and Deflection				Uniform Load @ Deflection =			
			Lbs. kN		In. mm		¹ / ₂₄₀ Span Lbs. kN		¹ / ₃₆₀ Span Lbs. kN	
12	(305)	B24	1750	(7.78)	.014	(.35)	1750	(7.78)	1750	(7.78)
		B24A	1750*	(7.78)	.002	(.05)	1750*	(7.78)	1750*	(7.78)
24	(609)	B24	1379	(6.13)	.057	(1.45)	1379	(6.13)	1379	(6.13)
		B24A	1750*	(7.78)	.014	(.35)	1750*	(7.78)	1750*	(7.78)
36	(914)	B24	919	(4.09)	.128	(3.25)	919	(4.09)	720	(3.20)
		B24A	1750*	(7.78)	.048	(1.22)	1750*	(7.78)	1750*	(7.78)
48	(1219)	B24	689	(3.06)	.227	(5.76)	607	(2.70)	405	(1.80)
		B24A	1750*	(7.78)	.115	(2.92)	1750*	(7.78)	1750*	(7.78)
60	(1524)	B24	551	(2.45)	.355	(9.02)	389	(1.73)	259	(1.15)
		B24A	1518	(6.75)	.195	(4.95)	1518	(6.75)	1294	(5.75)
72	(1829)	B24	460	(2.04)	.511	(12.98)	270	(1.20)	180	(0.80)
		B24A	1265	(5.63)	.281	(7.14)	1265	(5.63)	898	(3.99)
84	(2133)	B24	394	(1.75)	.695	(17.65)	198	(0.88)	132	(0.59)
		B24A	1084	(4.82)	.383	(9.73)	990	(4.40)	660	(2.93)
96	(2438)	B24	345	(1.53)	.908	(23.06)	152	(0.67)	101	(0.45)
		B24A	949	(4.22)	.500	(12.70)	758	(3.37)	505	(2.24)
108	(2743)	B24	306	(1.36)	1.149	(29.18)	120	(0.53)	80	(0.35)
		B24A	843	(3.75)	.633	(16.08)	599	(2.66)	399	(1.77)
120	(3048)	B24	276	(1.23)	1.419	(36.04)	97	(0.43)	65	(0.29)
		B24A	759	(3.37)	.782	(19.86)	485	(2.16)	323	(1.44)

Based on simple beam condition using an allowable design stress of 25,000 psi (172 MPa) in accordance with MFMA, with adequate lateral bracing (see page 12 for further explanation). Actual yield point of cold rolled steel is 42,000 psi. To determine concentrated load capacity at mid span, multiply uniform load by 0.5 and corresponding deflection by 0.8. *Failure determined by weld shear.

Column Loading

Unbraced Height In. mm		Channel Style	Max. Column Loading K = .80				Max. Column Loading (Loaded @ C.G.)					
			Loaded@ C.G.		Loaded@ Slot Face		K = .65		K = 1.0		K = 1.2	
			Lbs.	kN	Lbs.	kN	Lbs.	kN	Lbs.	kN	Lbs.	kN
12	(305)	B24	6441	(28.65)	3077	(13.69)	6509	(28.95)	6330	(28.16)	6198	(27.57)
		B24A	13212	(58.77)	4988	(22.19)	13237	(58.88)	13171	(58.59)	13121	(58.36)
24	(609)	B24	5874	(26.13)	2896	(12.88)	6124	(27.24)	5483	(24.39)	5038	(22.41)
		B24A	12993	(57.79)	4924	(21.90)	13092	(58.23)	12828	(57.06)	12627	(56.17)
36	(914)	B24	5038	(22.41)	2619	(11.65)	5535	(24.62)	4302	(19.13)	3516	(15.64)
		B24A	12627	(56.17)	4819	(21.43)	12851	(57.16)	12256	(54.52)	11804	(52.51)
48	(1219)	B24	4043	(17.98)	2272	(10.10)	4800	(21.35)	3008	(13.38)	2324	(10.34)
		B24A	12115	(53.89)	4675	(20.79)	12512	(55.65)	11456	(50.96)	10651	(47.38)
60	(1524)	B24	3008	(13.38)	1873	(8.33)	3978	(17.69)	2200	(9.78)	1740	(7.74)
		B24A	11456	(50.96)	4020	(17.88)	12078	(53.72)	10427	(46.38)	9169	(40.78)
72	(1829)	B24	2324	(10.34)	1562	(6.95)	3123	(13.89)	1740	(7.74)	1397	(6.21)
		B24A	10651	(47.38)	3048	(13.56)	11546	(51.36)	9169	(40.78)	7358	(32.73)
84	(2133)	B24	1898	(8.44)	1340	(5.96)	2502	(11.13)	1444	(6.42)	1168	(5.19)
		B24A	9700	(43.15)	2362	(10.50)	10918	(48.56)	7683	(34.17)	5464	(24.30)
96	(2438)	B24	1608	(7.15)	1175	(5.22)	2089	(9.29)	1236	(5.50)	1000	(4.45)
		B24A	8602	(38.26)	1866	(8.30)	10194	(45.34)	6024	(26.79)	4184	(18.61)
108	(2743)	B24	1397	(6.21)	1046	(4.65)	1796	(7.99)	1078	(4.79)	870**	(3.87)
		B24A	7358	(32.73)	1498	(6.66)	9373	(41.69)	4760	(21.17)	3306	(14.70)
120	(3048)	B24	1236	(5.50)	942	(4.19)	1578	(7.02)	953**	(4.24)	764**	(3.40)
		B24A	6024	(26.79)	1216	(5.41)	8455	(37.61)	3856	(17.15)	2677**	(11.91)

**Where the slenderness ratio $\frac{KL}{r}$ exceeds 200, and K = end fixity factor, L = actual length and r = radius of gyration.

Reference page 48 for general fitting and standard finish specifications.

B26 Channel & combinations

B26

- Thickness: 16 Gauge (1.5 mm)
- Standard lengths: 10' (3.05 m) & 20' (6.09 m)
- Standard finishes: Plain, DURA GREEN™, Pre-Galvanized
- Weight: 1.12 Lbs./Ft. (1.66 kg/m)

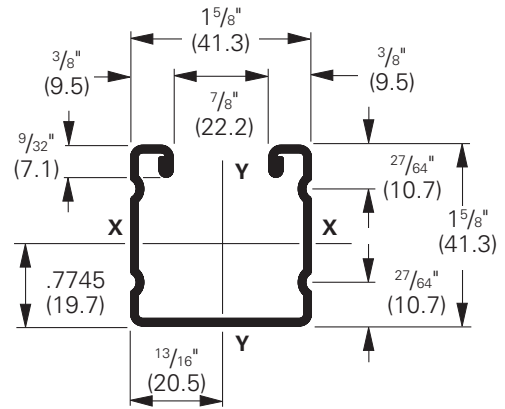

Section Properties

Channel	Weight lbs./ft. kg/m	Areas of Section sq. in. cm ²	X - X Axis			Y - Y Axis		
			Moment of Inertia (I) in. ⁴ cm ⁴	Section Modulus (S) in. ³ cm ³	Radius of Gyration (r) in. cm	Moment of Inertia (I) in. ⁴ cm ⁴	Section Modulus (S) in. ³ cm ³	Radius of Gyration (r) in. cm
B26	1.234 (1.84)	.363 (2.34)	.1337 (5.57)	.1581 (2.59)	.607 (1.54)	.1564 (6.51)	.1925 (3.15)	.656 (1.67)
B26A	2.467 (3.67)	.726 (4.68)	.7086 (29.49)	.4361 (7.15)	.988 (2.51)	.3128 (13.02)	.3850 (6.31)	.656 (1.67)

Calculations of section properties are based on metal thicknesses as determined by the AISI Cold-Formed Steel Design Manual.

Channel & Combinations

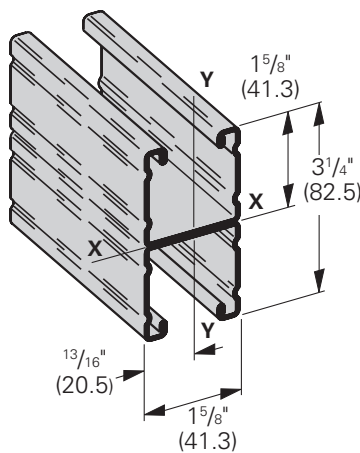

B26A

Wt. 2.24 Lbs./Ft. (3.33 kg/m)

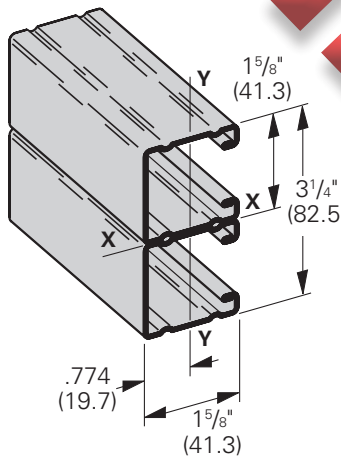

B26B

Wt. 2.24 Lbs./Ft. (3.33 kg/m)

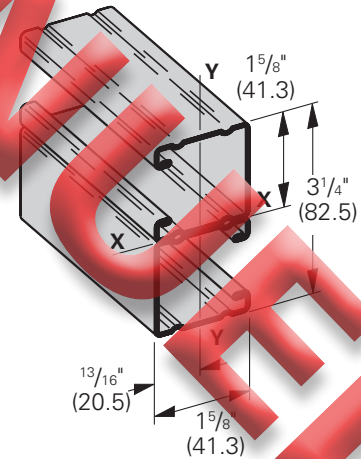

B26C

Wt. 2.24 Lbs./Ft. (3.33 kg/m)

Reference page 48 for general fitting and standard finish specifications.

B26 Beam & column loading data

Beam Loading

Beam Span In. mm	Channel Style	Uniform Load and Deflection				Uniform Load @ Deflection =			
		Lbs. kN		In. mm		1/240 Span		1/360 Span	
		Lbs.	kN	In.	mm	Lbs.	kN	Lbs.	kN
12 (305)	B26	1220	(5.43)	.014	(.35)	1220	(5.43)	1220	(5.43)
	B26A	1220*	(5.43)	.001	(.02)	1220*	(5.43)	1220*	(5.43)
24 (609)	B26	1163	(5.17)	.057	(1.45)	1163	(5.17)	1163	(5.17)
	B26A	1220*	(5.43)	.012	(.30)	1220*	(5.43)	1220*	(5.43)
36 (914)	B26	775	(3.45)	.128	(3.25)	775	(3.45)	603	(2.68)
	B26A	1220*	(5.43)	.040	(1.01)	1220*	(5.43)	1220*	(5.43)
48 (1219)	B26	581	(2.58)	.228	(5.79)	509	(2,264)	339	(1.51)
	B26A	1220*	(5.43)	.096	(2.44)	1220*	(5.43)	1220*	(5.43)
60 (1524)	B26	465	(2.07)	.357	(9.07)	326	(1,45)	217	(0.96)
	B26A	1220*	(5.43)	.188	(4.77)	1220*	(5.43)	1076	(4.78)
72 (1829)	B26	388	(1.72)	.514	(13.05)	226	(1,45)	151	(0.96)
	B26A	1052	(4.68)	.281	(7.14)	1052	(4,68)	747	(3.32)
84 (2133)	B26	332	(1.48)	.699	(17.75)	166	(0.74)	111	(0.49)
	B26A	902	(4.01)	.383	(9.73)	824	(3.66)	549	(2.44)
96 (2438)	B26	291	(1.29)	.913	(23.19)	127	(0.56)	85	(0.38)
	B26A	789	(3.51)	.500	(12.70)	631	(2.81)	420	(1.87)
108 (2743)	B26	258	(1.15)	1.156	(29.36)	101	(0.45)	67	(0.30)
	B26A	702	(3.12)	.633	(16.08)	498	(2.21)	332	(1.48)
120 (3048)	B26	233	(1.03)	1.427	(36.24)	81	(0.36)	54	(0.24)
	B26A	631	(2.17)	.782	(19.86)	404	(1.80)	269	(1.19)

Based on simple beam condition using an allowable design stress of 25,000 psi (172 MPa) in accordance with MFMA, with adequate lateral bracing (see page 12 for further explanation). Actual yield point of cold rolled steel is 42,000 psi. To determine concentrated load capacity at mid span, multiply uniform load by 0.5 and corresponding deflection by 0.8. Failure determined by weld shear.

Column Loading

Unbraced Height In. mm	Channel Style	Max. Column Loading K = .80				Max. Column Loading (Loaded @ C.G.)							
		Loaded@ C.G.		Loaded@ Slot Face		K = .65		K = 1.0		K = 1.2			
		Lbs.	kN	Lbs.	kN	Lbs.	kN	Lbs.	kN	Lbs.	kN		
12 (305)	B26	4002	(17.80)	2216	(9.86)	4032	(17.93)	3952	(17.58)	3891	(17.31)		
	B26A	8151	(36.26)	3630	(16.15)	8163	(36.31)	8133	(36.18)	8109	(36.07)		
24 (609)	B26	3740	(16.63)	2109	(9.38)	3857	(17.16)	3554	(15.81)	3336	(14.84)		
	B26A	8051	(35.81)	3591	(15.97)	8096	(36.04)	7975	(35.47)	7883	(35.06)		
36 (914)	B26	3336	(14.49)	1941	(8.63)	3579	(15.92)	2952	(13.17)	2546	(11.32)		
	B26A	7883	(35.06)	3528	(15.69)	7986	(35.52)	7713	(34.31)	7505	(33.38)		
48 (1219)	B26	2828	(12.58)	1725	(7.61)	3217	(14.31)	2251	(10.01)	1705	(7.58)		
	B26A	7648	(34.02)	3441	(15.30)	7831	(34.83)	7346	(32.67)	6977	(31.03)		
60 (1524)	B26	2251	(10.01)	1469	(6.53)	2793	(12.42)	1603	(7.13)	1233	(5.48)		
	B26A	7346	(32.67)	3066	(13.64)	7631	(33.94)	6874	(30.58)	6298	(28.01)		
72 (1829)	B26	1705	(7.58)	1203	(5.35)	2326	(10.34)	1233	(5.48)	967	(4.30)		
	B26A	6977	(31.03)	2385	(10.61)	7388	(32.86)	6298	(28.01)	5467	(24.32)		
84 (2133)	B26	1358	(6.04)	1011	(4.50)	1851	(8.23)	1003	(4.46)	797	(3.54)		
	B26A	6541	(29.09)	1884	(8.38)	7100	(31.58)	5616	(24.98)	4486	(19.95)		
96 (2438)	B26	1129	(5.02)	871	(3.87)	1513	(6.73)	847	(3.77)	630	(3.02)		
	B26A	6038	(26.86)	1512	(6.72)	6767	(30.10)	4830	(21.48)	3463	(15.40)		
108 (2743)	B26	967	(4.30)	766	(3.41)	1277	(5.68)	734	(3.26)	592**	(2.63)		
	B26A	5467	(24.32)	1231	(5.47)	6391	(28.43)	3940	(17.52)	2736	(12.17)		
120 (3048)	B26	847	(3.77)	684	(3.04)	1105	(4.91)	648	(2.88)	523**	(2.32)		
	B26A	4830	(21.48)	1015	(4.51)	5970	(26.55)	3192	(14.20)	2216**	(9.86)		

**Where the slenderness ratio $\frac{KL}{r}$ exceeds 200, and K = end fixity factor, L = actual length and r = radius of gyration.

Reference page 48 for general fitting and standard finish specifications.

B32 Channel & combinations

B32

- Thickness: 12 Gauge (2.6 mm)
- Standard lengths: 10' (3.05 m) & 20' (6.09 m)
- Standard finishes: Plain, DURA GREEN™, Pre-Galvanized, Hot-Dipped Galvanized, Stainless Steel Type 304
- Weight: 1.70 Lbs./Ft. (2.53 kg/m)

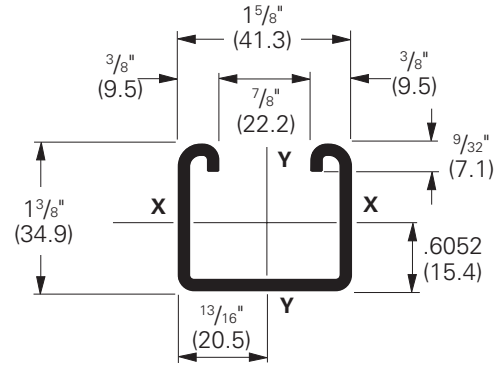
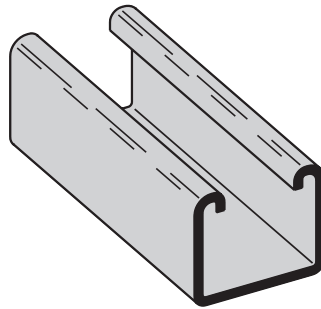

Section Properties			X - X Axis			Y - Y Axis		
Channel	Weight lbs./ft. kg/m	Areas of Section sq. in. cm ²	Moment of Inertia (I) in. ⁴ cm ⁴	Section Modulus (S) in. ³ cm ³	Radius of Gyration (r) in. cm	Moment of Inertia (I) in. ⁴ cm ⁴	Section Modulus (S) in. ³ cm ³	Radius of Gyration (r) in. cm
B32	1.733 (2.58)	.510 (3.29)	.1252 (5.21)	.1626 (2.67)	.496 (1.26)	.2098 (8.73)	.2582 (4.23)	.642 (1.63)
B32A	3.467 (5.16)	1.020 (6.58)	.6238 (25.96)	.4537 (7.43)	.782 (1.99)	.4195 (17.46)	.5163 (8.46)	.642 (1.63)

Calculations of section properties are based on metal thicknesses as determined by the AISI Cold-Formed Steel Design Manual.

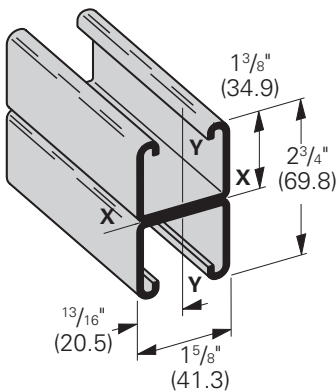

B32A

Wt. 3.40 Lbs./Ft. (5.06 kg/m)

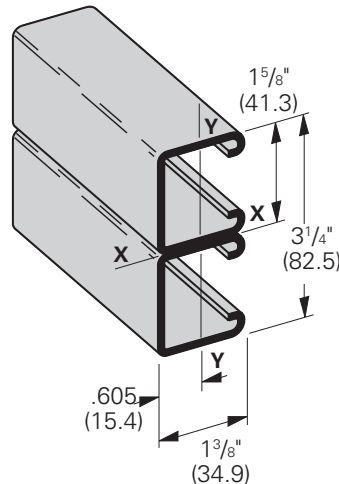

B32B

Wt. 3.40 Lbs./Ft. (5.06 kg/m)

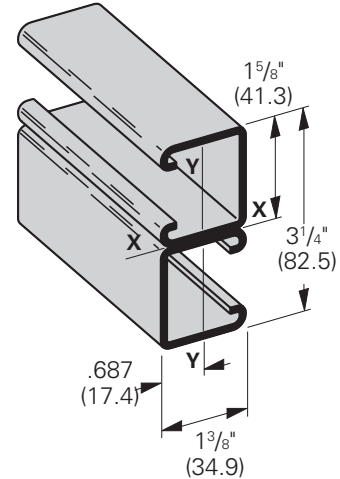

B32C

Wt. 3.40 Lbs./Ft. (5.06 kg/m)

Reference page 48 for general fitting and standard finish specifications.

B32 Beam & column loading data

Beam Loading

Beam Span In. mm		Channel Style	Uniform Load and Deflection				Uniform Load @ Deflection =			
			Lbs. kN		In. mm		1/240 Span		1/360 Span	
			Lbs.	kN	In.	mm	Lbs.	kN	Lbs.	kN
12	(305)	B32	2210	(9.83)	.016	(.40)	2210	(9.83)	2210	(9.83)
		B32A	2210*	(9.83)	.003	(.07)	2210*	(9.83)	2210*	(9.83)
24	(609)	B32	1299	(5.78)	.065	(1.65)	1299	(5.78)	1299	(5.78)
		B32A	2210*	(9.83)	.022	(.56)	2210*	(9.83)	2210*	(9.83)
36	(914)	B32	866	(3.85)	.147	(3.73)	866	(3.85)	587	(2.61)
		B32A	2210*	(9.83)	.076	(1.93)	2210*	(9.83)	2210*	(9.83)
48	(1219)	B32	649	(2.89)	.262	(6.65)	495	(2.20)	330	(1.47)
		B32A	1817	(8.08)	.148	(3.76)	1817	(8.08)	1638	(7.28)
60	(1524)	B32	520	(2.31)	.410	(10.41)	317	(1.41)	211	(0.94)
		B32A	1454	(6.47)	.231	(5.87)	1454	(6.47)	1048	(4.66)
72	(1829)	B32	433	(1.92)	.590	(14.98)	220	(0.98)	147	(0.65)
		B32A	1211	(5.39)	.333	(8.46)	1092	(4.86)	728	(3.24)
84	(2133)	B32	371	(1.65)	.803	(20.39)	162	(0.72)	108	(0.48)
		B32A	1038	(4.62)	.453	(11.50)	802	(3.57)	535	(2.38)
96	(2438)	B32	325	(1.44)	1.049	(26.64)	124	(0.55)	83	(0.37)
		B32A	909	(4.04)	.591	(15.01)	614	(2.73)	410	(1.82)
108	(2743)	B32	289	(1.28)	1.327	(33.70)	98	(0.43)	65	(0.29)
		B32A	808	(3.59)	.749	(19.02)	485	(2.16)	324	(1.44)
120	(3048)	B32	260	(1.15)	1.639	(41.63)	79	(0.35)	53	(0.23)
		B32A	727	(3.23)	.924	(23.47)	393	(1.75)	262	(1.16)

Based on simple beam condition using an allowable design stress of 25,000 psi (172 MPa) in accordance with MFMA, with adequate lateral bracing (see page 12 for further explanation). Actual yield point of cold rolled steel is 42,000 psi. To determine concentrated load capacity at mid span, multiply uniform load by 0.5 and corresponding deflection by 0.8. *Failure determined by weld shear.

Column Loading

Unbraced Height In. mm	Channel Style	Max. Column Loading K = .80				Max. Column Loading (Loaded @ C.G.)						
		Loaded@ C.G.		Loaded@ Slot Face		K = .65		K = 1.0		K = 1.2		
		Lbs.	kN	Lbs.	kN	Lbs.	kN	Lbs.	kN	Lbs.	kN	
12	(305)	B32	10278	(4.572)	4036	(17.95)	10432	(46.40)	10035	(44.64)	9753	(43.38)
		B32A	21320	(94.83)	6557	(29.17)	21378	(95.09)	21224	(94.41)	21106	(93.88)
24	(609)	B32	9104	(40.49)	3732	(16.60)	9600	(42.70)	8387	(37.31)	7640	(33.98)
		B32A	20806	(92.55)	6431	(28.60)	21039	(93.58)	20421	(90.84)	19950	(88.74)
36	(914)	B32	7640	(33.98)	3323	(14.78)	8479	(37.71)	6520	(29.00)	5425	(24.13)
		B32A	19950	(88.74)	6228	(27.70)	20474	(91.07)	19083	(84.88)	18023	(80.17)
48	(1219)	B32	6151	(27.36)	2877	(12.80)	7265	(32.31)	4778	(21.25)	3870	(17.21)
		B32A	18751	(83.41)	5954	(26.48)	19682	(87.55)	17210	(76.55)	15326	(68.17)
60	(1524)	B32	4778	(21.25)	2435	(10.83)	6060	(26.95)	3693	(16.43)	2994	(13.32)
		B32A	17210	(76.55)	4692	(20.87)	18665	(83.02)	14801	(65.84)	11858	(52.75)
72	(1829)	B32	3870	(17.21)	2089	(9.29)	4923	(21.90)	2994	(13.32)	2403	(10.68)
		B32A	15326	(68.17)	3448	(15.34)	17421	(77.49)	11858	(52.75)	8316	(36.99)
84	(2133)	B32	3243	(14.42)	1817	(8.08)	4114	(18.30)	2489	(11.07)	1807**	(8.04)
		B32A	13100	(58.27)	2609	(11.60)	15951	(70.95)	8798	(39.13)	6110	(27.18)
96	(2438)	B32	2774	(12.34)	1594	(7.09)	3531	(15.70)	1993	(8.86)	1384**	(6.15)
		B32A	10525	(46.82)	2014	(8.96)	14256	(63.41)	6736	(29.96)	4678	(20.81)
108	(2743)	B32	2403	(10.69)	1407	(6.26)	3083	(13.71)	1574**	(7.00)	1093**	(4.86)
		B32A	8316	(36.99)	1592	(7.08)	12334	(54.86)	5322	(23.67)	3696**	(16.44)
120	(3048)	B32	1993	(8.86)	1221	(5.43)	2723	(12.11)	1275**	(5.67)	886**	(3.94)
		B32A	6736	(29.96)	1289	(5.73)	10203	(45.38)	4311	(19.17)	2994**	(13.32)

**Where the slenderness ratio $\frac{KL}{r}$ exceeds 200, and K = end fixity factor, L = actual length and r = radius of gyration.

Reference page 48 for general fitting and standard finish specifications.

B42 Channel & combinations

B42

- Thickness: 12 Gauge (2.6 mm)
- Standard lengths: 10' (3.05 m) & 20' (6.09 m)
- Standard finishes: Plain, DURA GREEN™, Pre-Galvanized, Hot-Dipped Galvanized, Stainless Steel Type 304
- Weight: 1.44 Lbs./Ft. (2.14 kg/m)

Note: Also available in 14 gauge (1.9mm) material as B44

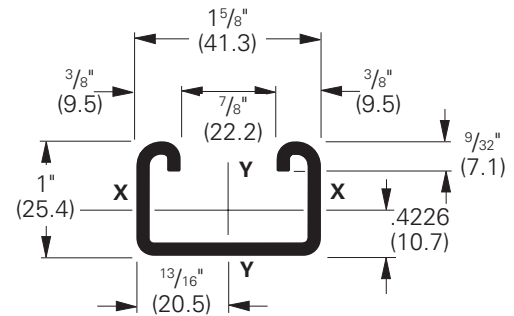
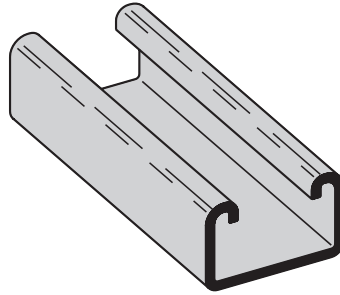

Section Properties			X - X Axis			Y - Y Axis		
Channel	Weight lbs./ft. kg/m	Areas of Section sq. in. cm ²	Moment of Inertia (I) in. ⁴ cm ⁴	Section Modulus (S) in. ³ cm ³	Radius of Gyration (r) in. cm	Moment of Inertia (I) in. ⁴ cm ⁴	Section Modulus (S) in. ³ cm ³	Radius of Gyration (r) in. cm
B42	1.468 (2.18)	.432 (2.79)	.0554 (2.31)	.0968 (1.59)	.358 (.91)	.1645 (6.85)	.2025 (3.32)	.617 (1.57)
B42A	2.936 (4.37)	.864 (5.57)	.2689 (11.19)	.2689 (4.41)	.558 (1.42)	.3292 (13.70)	.4052 (6.64)	.617 (1.57)

Calculations of section properties are based on metal thicknesses as determined by the AISI Cold-Formed Steel Design Manual.

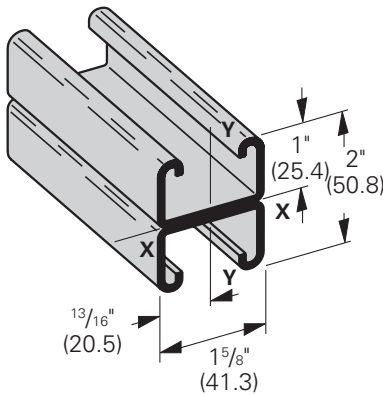

B42A
Wt. 2.88 Lbs./Ft. (4.28 kg/m)

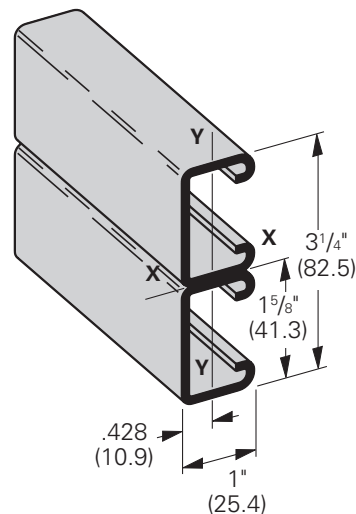

B42B
Wt. 2.88 Lbs./Ft. (4.28 kg/m)

Reference page 48 for general fitting and standard finish specifications.

B42 Beam & column loading data

Beam Loading

Beam Span In. mm	Channel Style	Uniform Load and Deflection				Uniform Load @ Deflection =			
		Lbs.	kN	In.	mm	¹ / ₂₄₀ Span		¹ / ₃₆₀ Span	
		Lbs.	kN	In.	mm	Lbs.	kN	Lbs.	kN
12 (305)	B42	1538	(6.84)	.022	(.56)	1538	(6.84)	1538	(6.84)
	B42A	1590*	(7.07)	.005	(.13)	1590*	(7.07)	1590*	(7.07)
24 (609)	B42	769	(3.42)	.088	(2.23)	769	(3.42)	582	(2.59)
	B42A	1590*	(7.07)	.038	(.96)	1590*	(7.07)	1590*	(7.07)
36 (914)	B42	513	(2.28)	.198	(5.03)	388	(1.72)	259	(1.15)
	B42A	1428	(6.35)	.114	(2.89)	1428	(6.35)	1248	(5.55)
48 (1219)	B42	384	(1.71)	.352	(8.94)	218	(0.97)	145	(0.64)
	B42A	1071	(4.76)	.203	(5.15)	1053	(4.68)	702	(3.12)
60 (1524)	B42	308	(1.37)	.550	(13.97)	140	(0.62)	93	(0.41)
	B42A	857	(3.81)	.318	(8.08)	674	(3.00)	449	(2.00)
72 (1829)	B42	256	(1.14)	.792	(20.11)	97	(0.43)	65	(0.29)
	B42A	714	(3.17)	.457	(11.61)	468	(2.08)	312	(1.39)
84 (2133)	B42	220	(0.98)	1.079	(27.40)	71	(0.31)	48	(0.21)
	B42A	612	(2.72)	.623	(15.82)	344	(1.53)	229	(1.02)
96 (2438)	B42	192	(0.85)	1.409	(35.79)	55	(0.24)	36	(0.16)
	B42A	535	(2.38)	.813	(20.65)	263	(1.17)	176	(0.78)
108 (2743)	B42	171	(0.76)	1.783	(45.29)	43	(0.19)	29	(0.13)
	B42A	476	(2.12)	1.029	(26.13)	208	(0.92)	139	(0.62)
120 (3048)	B42	154	(0.68)	2.202	(55.93)	35	(0.15)	23	(0.10)
	B42A	428	(1.90)	1.271	(32.28)	168	(0.75)	112	(0.50)

Based on simple beam condition using an allowable design stress of 25,000 psi (172 MPa) in accordance with MFMA, with adequate lateral bracing (see page 12 for further explanation). Actual yield point of cold rolled steel is 42,000 psi. To determine concentrated load capacity at mid span, multiply uniform load by 0.5 and corresponding deflection by 0.8. *Failure determined by weld shear.

Column Loading

Unbraced Height In. mm	Channel Style	Max. Column Loading K = .80				Max. Column Loading (Loaded @ C.G.)					
		Loaded@ C.G.		Loaded@ Slot Face		K = .65		K = 1.0		K = 1.2	
		Lbs.	kN	Lbs.	kN	Lbs.	kN	Lbs.	kN	Lbs.	kN
12 (305)	B42	9138	(40.65)	3493	(15.54)	9283	(41.23)	8916	(39.66)	8670	(38.56)
	B42A	21094	(93.83)	5834	(25.95)	21304	(94.76)	20793	(92.49)	20469	(91.05)
24 (609)	B42	8137	(36.19)	3145	(13.99)	8540	(37.99)	7589	(33.76)	7050	(31.36)
	B42A	19757	(87.88)	5585	(24.84)	20299	(90.29)	18964	(84.35)	18094	(80.48)
36 (914)	B42	7050	(31.36)	2722	(12.11)	7657	(34.06)	5925	(26.35)	4335	(19.28)
	B42A	18094	(80.48)	5237	(23.29)	19067	(84.81)	16654	(74.08)	15057	(66.98)
48 (1219)	B42	5405	(24.04)	2227	(9.90)	6786	(30.18)	3512	(15.62)	2439	(10.85)
	B42A	16139	(71.79)	4818	(21.43)	17632	(78.43)	13906	(61.86)	11387	(50.65)
60 (1524)	B42	3512	(15.62)	1718	(7.64)	5272	(23.45)	2247	(9.99)	1561**	(6.94)
	B42A	13906	(61.86)	4352	(19.36)	16008	(71.21)	10710	(47.64)	7531	(33.50)
72 (1829)	B42	2439	(10.85)	1351	(6.01)	3694	(16.43)	1561**	(6.94)	1084**	(4.82)
	B42A	11387	(50.65)	3856	(17.15)	14200	(64.16)	7531	(33.50)	5230	(23.26)
84 (2133)	B42	1792	(7.97)	1087	(4.83)	2714	(12.07)	1147**	(5.10)	796**	(3.54)
	B42A	8645	(38.45)	3332	(14.82)	12206	(54.29)	5533	(24.61)	3842	(17.09)
96 (2438)	B42	1372**	(6.10)	891	(3.96)	2078	(9.24)	878**	(3.90)	-	-
	B42A	6619	(29.44)	2873	(12.78)	10012	(44.53)	4236	(18.84)	2942**	(13.08)
108 (2743)	B42	1084**	(4.82)	743	(3.30)	1642	(7.30)	-	-	-	-
	B42A	5230	(23.26)	2495	(11.10)	7922	(35.24)	3347	(14.89)	2324**	(10.34)
120 (3048)	B42	878**	(3.90)	628	(2.79)	1330**	(5.91)	-	-	-	-
	B42A	4236	(18.84)	2182	(9.70)	6417	(28.54)	2711**	(12.06)	1883**	(8.37)

**Where the slenderness ratio $\frac{KL}{r}$ exceeds 200, and K = end fixity factor, L = actual length and r = radius of gyration.

Reference page 48 for general fitting and standard finish specifications.

B52 Channel & combinations

B52

- Thickness: 12 Gauge (2.6 mm)
- Standard lengths: 10' (3.05 m) & 20' (6.09 m)
- Standard finishes: Plain, DURA GREEN™, Pre-Galvanized, Stainless Steel Type 304 or 316, Hot-Dipped Galvanized
- Weight: 1.27 Lbs./Ft. (1.89 kg/m)

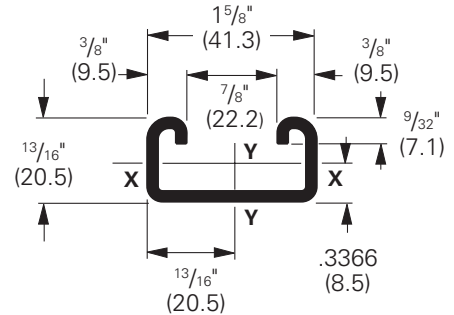
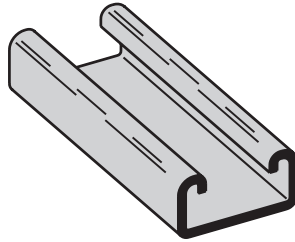

Section Properties			X - X Axis				Y - Y Axis				
Channel	Weight		Areas of Section sq. in. cm ²	Moment of Inertia (I) in. ⁴ cm ⁴	Section Modulus (S) in. ³ cm ³	Radius of Gyration (r)		Moment of Inertia (I) in. ⁴ cm ⁴	Section Modulus (S) in. ³ cm ³	Radius of Gyration (r)	
	lbs./ft.	kg/m				in.	cm			in.	cm
B52	1.313	(1.95)	.386 (2.49)	.0320 (1.33)	.0673 (1.10)	.288	(.73)	.1404 (5.84)	.1728 (2.83)	.603	(1.53)
B52A	2.627	(3.91)	.773 (4.99)	.1517 (6.31)	.1868 (3.06)	.443	(1.13)	.2809 (11.69)	.3457 (5.67)	.603	(1.53)

Calculations of section properties are based on metal thicknesses as determined by the AISI Cold-Formed Steel Design Manual.

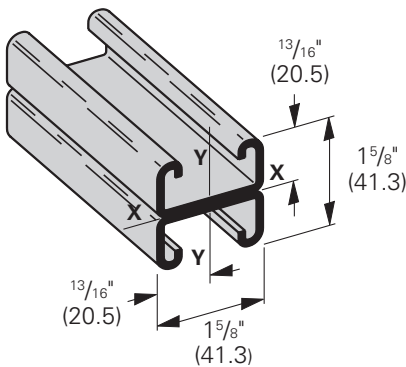

B52A
Wt. 2.54 Lbs./Ft. (3.78 kg/m)

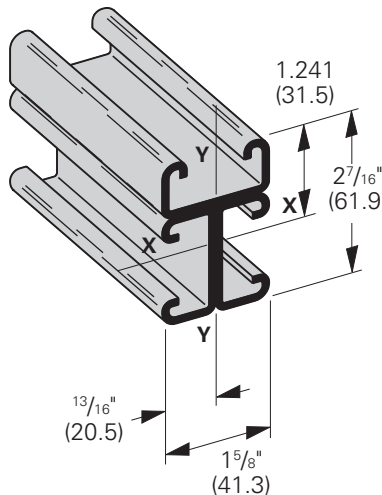

B52B3
Wt. 3.81 Lbs./Ft. (5.67 kg/m)

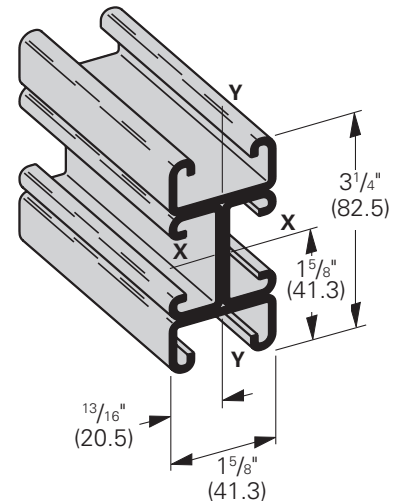

B52B4
Wt. 5.08 Lbs./Ft. (7.56 kg/m)

Reference page 48 for general fitting and standard finish specifications.

B52 Beam & column loading data

Beam Loading

Beam Span In. mm	Channel Style	Uniform Load and Deflection				Uniform Load @ Deflection =			
		Lbs.	kN	In.	mm	1/240 Span		1/360 Span	
		Lbs.	kN	In.	mm	Lbs.	kN	Lbs.	kN
12 (305)	B52	1079	(4.80)	.026	(.66)	1079	(4.80)	1079	(4.80)
	B52A	1270*	(5.65)	.006	(.15)	1270*	(5.65)	1270*	(5.65)
24 (609)	B52	539	(2.40)	.106	(2.69)	506	(2.25)	337	(1.50)
	B52A	1270*	(5.65)	.052	(1.32)	1270*	(5.65)	1270*	(5.65)
36 (914)	B52	360	(1.60)	.240	(6.09)	225	(1.00)	150	(0.67)
	B52A	1013	(4.50)	.141	(3.58)	1013	(4.50)	719	(3.20)
48 (1219)	B52	270	(1.20)	.427	(10.84)	126	(0.56)	84	(0.37)
	B52A	759	(3.37)	.250	(6.35)	607	(2.70)	404	(1.80)
60 (1524)	B52	216	(0.96)	.667	(16.94)	81	(0.36)	54	(0.24)
	B52A	608	(2.70)	.391	(9.93)	388	(1.72)	259	(1.15)
72 (1829)	B52	180	(0.80)	.960	(24.38)	56	(0.25)	37	(0.16)
	B52A	506	(.225)	.563	(14.30)	270	(1.20)	180	(0.80)
84 (2133)	B52	154	(0.68)	1.307	(33.20)	41	(0.18)	28	(0.12)
	B52A	434	(1.93)	.766	(19.45)	198	(0.88)	132	(0.59)
96 (2438)	B52	135	(0.60)	1.707	(43.36)	32	(0.14)	21	(0.09)
	B52A	380	(1.69)	1.001	(25.42)	152	(0.67)	101	(0.45)
108 (2743)	B52	120	(0.53)	2.160	(54.86)	25	(0.11)	17	(0.07)
	B52A	338	(1.50)	1.267	(32.18)	120	(0.53)	80	(0.35)
120 (3048)	B52	108	(0.48)	2.667	(67.74)	20	(0.09)	13	(0.06)
	B52A	304	(.135)	1.564	(39.72)	97	(0.43)	65	(0.29)

Based on simple beam condition using an allowable design stress of 25,000 psi (172 MPa) in accordance with MFMA, with adequate lateral bracing (see page 12 for further explanation). Actual yield point of cold rolled steel is 42,000 psi. To determine concentrated load capacity at mid span, multiply uniform load by 0.5 and corresponding deflection by 0.8. *Failure determined by weld shear.

Column Loading

Unbraced Height In. mm	Channel Style	Max. Column Loading K = .80				Max. Column Loading (Loaded @ C.G.)					
		Loaded@ C.G.		Loaded@ Slot Face		K = .65		K = 1.0		K = 1.2	
		Lbs.	kN	Lbs.	kN	Lbs.	kN	Lbs.	kN	Lbs.	kN
12 (305)	B52	8407	(37.36)	3162	(14.06)	8543	(38.00)	8205	(36.50)	7989	(35.54)
	B52A	19160	(85.23)	5290	(23.53)	19425	(86.41)	18777	(83.52)	18363	(81.68)
24 (609)	B52	7519	(33.44)	2755	(12.25)	7879	(35.05)	6521	(29.01)	5397	(24.01)
	B52A	17444	(77.59)	4955	(22.04)	18144	(80.71)	16412	(73.00)	15275	(67.94)
36 (914)	B52	5397	(24.01)	2152	(9.57)	6653	(29.59)	3616	(16.08)	2511	(11.17)
	B52A	15275	(67.94)	4496	(20.00)	16547	(73.60)	13376	(59.50)	11243	(50.01)
48 (1219)	B52	3178	(14.13)	1560	(6.94)	4785	(21.28)	2034	(9.05)	1412**	(6.28)
	B52A	12692	(56.46)	3963	(17.63)	14667	(65.24)	9683	(43.07)	6780	(30.16)
60 (1524)	B52	2034	(9.05)	1159	(5.15)	3081	(13.70)	1302**	(5.79)	904**	(4.02)
	B52A	9683	(43.07)	3383	(15.05)	12516	(55.67)	6248	(27.79)	4339	(19.30)
72 (1829)	B52	1412**	(6.28)	891	(3.96)	2139	(9.51)	904**	(4.02)	-	-
	B52A	6780	(30.16)	2799	(12.45)	10084	(44.85)	4339	(19.30)	3013	(13.42)
84 (2133)	B52	1038**	(4.62)	704	(3.13)	1572	(6.99)	664**	(2.95)	-	-
	B52A	4981	(22.15)	2337	(10.39)	7545	(33.56)	3188	(14.18)	2214**	(9.85)
96 (2438)	B52	794**	(3.53)	570	(2.53)	1203**	(5.35)	-	-	-	-
	B52A	3814	(16.96)	1973	(8.77)	5777	(25.70)	2441**	(10.86)	1695**	(7.54)
108 (2743)	B52	-	-	470	(2.09)	951**	(4.23)	-	-	-	-
	B52A	3013	(13.40)	1684	(7.49)	4564	(20.30)	1928**	(8.57)	1339**	(5.95)
120 (3048)	B52	-	-	394	(1.75)	770**	(3.42)	-	-	-	-
	B52A	2441**	(10.86)	1452	(6.46)	3697	(16.44)	1562**	(6.95)	-	-

**Where the slenderness ratio $\frac{L}{r}$ exceeds 200, and K = end fixity factor, L = actual length and r = radius of gyration.

Reference page 48 for general fitting and standard finish specifications.

B54 Channel & combinations

B54

- Thickness: 14 Gauge (1.9 mm)
- Standard lengths: 10' (3.05 m) & 20' (6.09 m)
- Standard finishes: Plain, DURA GREEN™, Pre-Galvanized, Hot-Dipped Galvanized, Stainless Steel Type 304 or 316, Aluminum
- Weight: .97 Lbs./Ft. (1.44 kg/m)

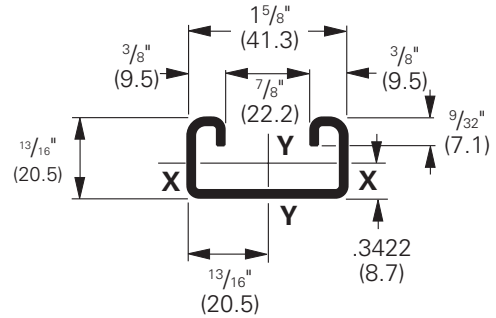
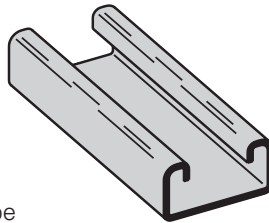

Note:

Aluminum loading, for B54 & B54A, can be determined by multiplying load data times a factor of 0.38

Section Properties			X - X Axis			Y - Y Axis		
Channel	Weight lbs./ft. kg/m	Areas of Section sq. in. cm ²	Moment of Inertia (I) in. ⁴ cm ⁴	Section Modulus (S) in. ³ cm ³	Radius of Gyration (r) in. cm	Moment of Inertia (I) in. ⁴ cm ⁴	Section Modulus (S) in. ³ cm ³	Radius of Gyration (r) in. cm
B54	1.016 (1.51)	.299 (1.93)	.0263 (1.09)	.0560 (.92)	.297 (.75)	.1106 (4.60)	.1361 (2.23)	.608 (1.55)
B54A	2.032 (3.02)	.598 (3.86)	.1226 (5.10)	.1510 (2.47)	.453 (1.15)	.2212 (9.12)	.2722 (4.46)	.608 (1.55)

Calculations of section properties are based on metal thicknesses as determined by the AISI Cold-Formed Steel Design Manual.

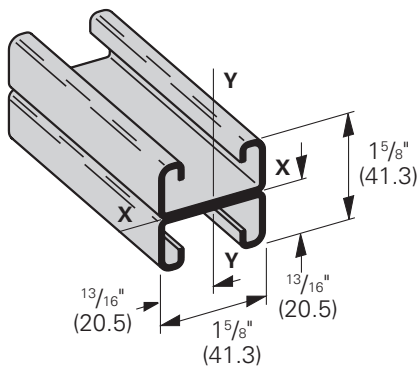

B54A

Wt. 1.94 Lbs./Ft. (2.89 kg/m)

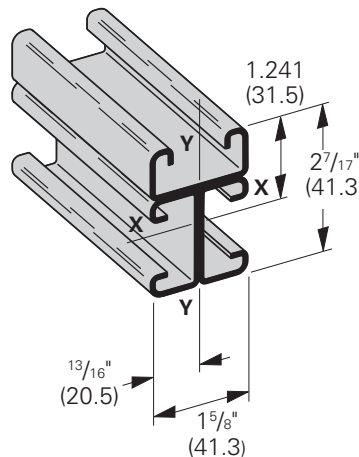

B54B3

Wt. 2.91 Lbs./Ft. (4.33 kg/m)

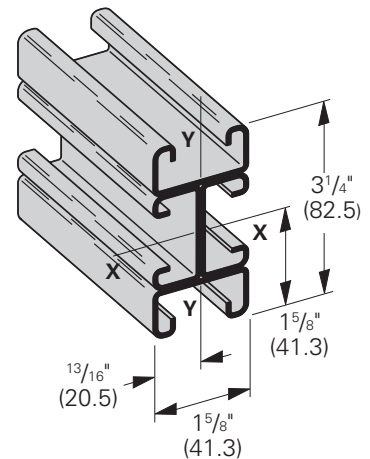

B54B4

Wt. 3.88 Lbs./Ft. (5.77 kg/m)

B54 Beam & column loading data

Beam Loading

Beam Span In. mm	Channel Style	Uniform Load and Deflection				Uniform Load @ Deflection =			
		Lbs.	kN	In.	mm	¹ / ₂₄₀ Span		¹ / ₃₆₀ Span	
		Lbs.	kN	In.	mm	Lbs.	kN	Lbs.	kN
12 (305)	B54	870	(3.87)	.027	(.68)	870	(3.87)	870	(3.87)
	B54A	870*	(3.87)	.005	(.13)	870*	(3.87)	870*	(3.87)
24 (609)	B54	465	(2.07)	.108	(2.74)	430	(1.91)	287	(1.27)
	B54A	870*	(3.87)	.043	(1.09)	870*	(3.87)	870*	(3.87)
36 (914)	B54	310	(1.38)	.243	(6.17)	191	(0.85)	127	(0.56)
	B54A	832	(3.70)	.141	(3.58)	832	(3.70)	591	(2.63)
48 (1219)	B54	233	(1.03)	.432	(10.97)	108	(0.48)	72	(0.32)
	B54A	624	(2.77)	.250	(6.35)	499	(2.22)	332	(1.48)
60 (1524)	B54	186	(0.83)	.676	(17.17)	69	(0.31)	46	(0.20)
	B54A	499	(2.22)	.391	(9.93)	319	(1.42)	213	(0.95)
72 (1829)	B54	155	(0.69)	.973	(24.71)	48	(0.21)	32	(0.14)
	B54A	416	(1.85)	.563	(14.30)	222	(0.99)	148	(0.66)
84 (2133)	B54	133	(0.59)	1.324	(33.63)	35	(0.15)	23	(0.10)
	B54A	357	(1.59)	.766	(19.45)	163	(0.72)	109	(0.48)
96 (2438)	B54	116	(0.51)	1.730	(43.94)	27	(0.12)	18	(0.08)
	B54A	312	(1.39)	1.001	(25.42)	125	(0.55)	83	(0.37)
108 (2743)	B54	103	(0.46)	2.189	(55.60)	21	(0.09)	14	(0.06)
	B54A	277	(1.23)	1.267	(32.18)	98	(0.43)	66	(0.29)
120 (3048)	B54	93	(0.41)	2.703	(68.65)	17	(0.07)	11	(0.05)
	B54A	250	(1.11)	1.564	(39.72)	80	(0.35)	53	(0.23)

Based on simple beam condition using an allowable design stress of 25,000 psi (172 MPa) in accordance with MFMA, with adequate lateral bracing (see page 12 for further explanation). Actual yield point of cold rolled steel is 42,000 psi. To determine concentrated load capacity at mid span, multiply uniform load by 0.5 and corresponding deflection by 0.8. *Failure determined by weld shear.

Column Loading

Unbraced Height In. mm	Channel Style	Max. Column Loading K = .80				Max. Column Loading (Loaded @ C.G.)					
		Loaded@ C.G.		Loaded@ Slot Face		K = .65		K = 1.0		K = 1.2	
		Lbs.	kN	Lbs.	kN	Lbs.	kN	Lbs.	kN	Lbs.	kN
12 (305)	B54	6186	(27.51)	2586	(11.50)	6284	(27.95)	6032	(26.83)	5857	(26.05)
	B54A	12763	(56.77)	4060	(18.06)	12835	(57.09)	12645	(56.25)	12501	(55.61)
24 (609)	B54	5464	(24.30)	2254	(10.02)	5763	(25.63)	4968	(22.10)	4300	(19.13)
	B54A	12135	(53.98)	3857	(17.16)	12420	(55.25)	11663	(51.88)	11087	(49.32)
36 (914)	B54	4300	(19.13)	1816	(8.08)	5043	(22.43)	3076	(13.68)	2136	(9.50)
	B54A	11087	(49.32)	3549	(15.79)	11728	(52.17)	10026	(44.60)	8729	(38.83)
48 (1219)	B54	2703	(12.02)	1341	(5.96)	3920	(17.44)	1730	(7.69)	1201	(5.34)
	B54A	9620	(42.79)	3169	(14.09)	10759	(47.86)	7734	(34.40)	5571	(24.78)
60 (1524)	B54	1730	(7.69)	995	(4.42)	2621	(11.66)	1107**	(4.92)	769**	(3.42)
	B54A	7734	(34.40)	2745	(12.21)	9514	(42.32)	5134	(22.84)	3566	(15.86)
72 (1829)	B54	1201	(5.34)	763	(3.39)	1820	(8.09)	769**	(3.42)	534**	(2.37)
	B54A	5571	(24.78)	2291	(10.19)	7992	(35.50)	3566	(15.86)	2476	(11.01)
84 (2133)	B54	883**	(3.93)	603	(2.68)	1337	(5.95)	565**	(2.51)	—	—
	B54A	4093	(18.20)	1913	(8.51)	6200	(27.58)	2620	(11.65)	1819**	(8.09)
96 (2438)	B54	676**	(3.01)	487	(2.16)	1024**	(4.55)	—	—	—	—
	B54A	3134	(13.94)	1616	(7.19)	4747	(21.11)	2006**	(8.92)	1393**	(6.19)
108 (2743)	B54	534**	(2.37)	401	(1.78)	809**	(3.60)	—	—	—	—
	B54A	2476	(11.01)	1380	(6.14)	3751	(16.68)	1585**	(7.05)	1100**	(4.89)
120 (3048)	B54	—	—	336	(1.49)	655**	(2.91)	—	—	—	—
	B54A	2006**	(8.92)	1190	(5.29)	3038	(13.51)	1284**	(5.71)	—	—

**Where the slenderness ratio $\frac{KL}{r}$ exceeds 200, and K = end fixity factor, L = actual length and r = radius of gyration.

Reference page 48 for general fitting and standard finish specifications.

B56 Channel & combinations

B56

- Thickness: 16 Gauge (1.5 mm)
- Standard lengths: 10' (3.05 m) & 20' (6.09 m)
- Standard finishes: Plain, DURA GREEN™, Pre-Galvanized, Hot-Dipped Galvanized
- Weight: .85 Lbs./Ft. (1.26 kg/m)

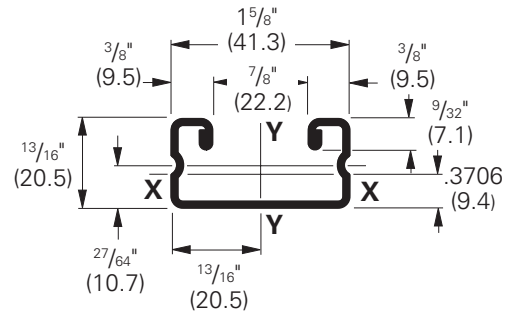

Section Properties

Channel	Weight lbs./ft. kg/m	Areas of Section sq. in. cm ²	X - X Axis			Y - Y Axis		
			Moment of Inertia (I) in. ⁴ cm ⁴	Section Modulus (S) in. ³ cm ³	Radius of Gyration (r) in. cm	Moment of Inertia (I) in. ⁴ cm ⁴	Section Modulus (S) in. ³ cm ³	Radius of Gyration (r) in. cm
B56	.894 (1.33)	.263 (1.70)	.0241 (1.00)	.0546 (1.89)	.303 (.77)	.0966 (4.02)	.1189 (1.95)	.606 (1.54)
B56A	1.789 (2.66)	.526 (3.39)	.1205 (5.02)	.1484 (2.43)	.479 (1.22)	.1931 (8.04)	.2377 (3.89)	.606 (1.54)

Calculations of section properties are based on metal thicknesses as determined by the AISI Cold-Formed Steel Design Manual.

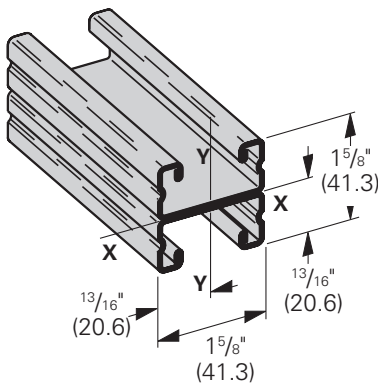

B56A

Wt. 1.70 Lbs./Ft. (2.53 kg/m)

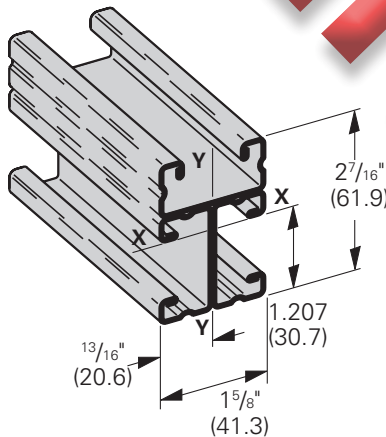

B56B3

Wt. 2.55 Lbs./Ft. (3.79 kg/m)

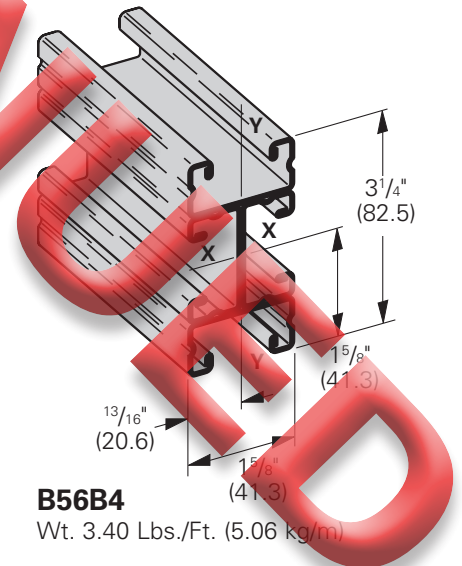

B56B4

Wt. 3.40 Lbs./Ft. (5.06 kg/m)

B56 Beam & column loading data

Beam Loading

Beam Span In. mm	Channel Style	Uniform Load and Deflection				Uniform Load @ Deflection =			
		Lbs.	kN	In.	mm	1/240 Span		1/360 Span	
		Lbs.	kN	In.	mm	Lbs.	kN	Lbs.	kN
12 (305)	B56	610	(2.73)	.027	(.68)	610	(2.71)	610	(2.71)
	B56A	610*	(2.71)	.004	(.10)	610*	(2.71)	610*	(2.71)
24 (609)	B56	405	(1.80)	.109	(2.77)	372	(1.65)	248	(1.10)
	B56A	610*	(2.71)	.035	(.89)	610*	(2.71)	610*	(2.71)
36 (914)	B56	270	(1.20)	.245	(6.22)	165	(0.73)	110	(0.49)
	B56A	610*	(2.71)	.121	(3.07)	610*	(2.71)	502	(2.23)
48 (1219)	B56	202	(0.90)	.435	(11.05)	93	(0.41)	62	(0.27)
	B56A	530	(2.36)	.250	(6.35)	423	(1.88)	282	(1.70)
60 (1524)	B56	162	(0.72)	.680	(17.27)	59	(0.26)	40	(0.18)
	B56A	424	(1.88)	.391	(9.93)	271	(1.20)	181	(0.80)
72 (1829)	B56	135	(0.60)	.980	(24.89)	41	(0.18)	28	(0.12)
	B56A	353	(1.57)	.563	(14.30)	188	(0.83)	125	(0.55)
84 (2133)	B56	116	(0.51)	1.334	(33.88)	30	(0.13)	20	(0.09)
	B56A	303	(1.35)	.766	(19.45)	138	(0.61)	92	(0.41)
96 (2438)	B56	101	(0.45)	1.742	(44.24)	23	(0.10)	15	(0.07)
	B56A	265	(1.18)	1.001	(25.42)	106	(0.47)	71	(0.31)
108 (2743)	B56	90	(0.40)	2.205	(56.01)	18	(0.08)	12	(0.05)
	B56A	236	(1.05)	1.267	(32.18)	84	(0.37)	56	(0.25)
120 (3048)	B56	81	(0.36)	2.722	(69.14)	15	(0.07)	10	(0.04)
	B56A	212	(0.94)	1.564	(39.72)	68	(0.30)	45	(0.20)

Based on simple beam condition using an allowable design stress of 25,000 psi (172 MPa) in accordance with MFMA, with adequate lateral bracing (see page 12 for further explanation). Actual yield point of cold rolled steel is 42,000 psi. To determine concentrated load capacity at mid span, multiply uniform load by 0.5 and corresponding deflection by 0.8. Failure determined by weld shear.

Column Loading

Unbraced Height In. mm	Channel Style	Max. Column Loading K = .80				Max. Column Loading (Loaded @ C.G.)					
		Loaded@ C.G.		Loaded@ Slot Face		K = .65		K = 1.0		K = 1.2	
		Lbs.	kN	Lbs.	kN	Lbs.	kN	Lbs.	kN	Lbs.	kN
12 (305)	B56	4968	(22.10)	2182	(9.70)	5044	(22.44)	4845	(21.55)	4702	(20.91)
	B56A	10237	(45.53)	3365	(14.97)	10291	(45.77)	10148	(45.14)	10039	(44.65)
24 (609)	B56	4367	(19.42)	1903	(8.46)	4624	(20.57)	3985	(17.72)	3572	(15.89)
	B56A	9762	(43.42)	3202	(14.24)	9977	(44.38)	9405	(41.83)	8969	(39.89)
36 (914)	B56	3572	(15.89)	1557	(6.92)	4034	(17.94)	2658	(11.82)	1845	(8.21)
	B56A	8969	(39.89)	2955	(13.14)	9454	(42.05)	8167	(36.33)	7186	(31.96)
48 (1219)	B56	2335	(10.38)	1164	(5.18)	3290	(14.63)	1495	(6.65)	1038	(4.62)
	B56A	7860	(34.96)	2649	(11.78)	8722	(38.80)	6434	(28.62)	4731	(21.04)
60 (1524)	B56	1495	(6.65)	862	(3.83)	2264	(10.07)	957	(4.26)	664**	(2.95)
	B56A	6434	(28.62)	2307	(10.26)	7780	(34.61)	4360	(19.39)	3028	(13.47)
72 (1829)	B56	1038	(4.62)	661	(2.94)	1572	(6.99)	664**	(2.95)	461**	(2.05)
	B56A	4731	(21.04)	1937	(8.61)	6629	(29.49)	3028	(13.47)	2103	(9.35)
84 (2133)	B56	763**	(3.39)	522	(2.32)	1155	(5.14)	488**	(2.17)	-	-
	B56A	3476	(15.46)	1619	(7.20)	5269	(23.44)	2224	(9.89)	1545**	(6.87)
96 (2438)	B56	584**	(2.60)	422	(1.88)	884**	(3.93)	-	-	-	-
	B56A	2661	(11.84)	1368	(6.08)	4031	(17.93)	1703**	(7.57)	1183**	(5.26)
108 (2743)	B56	461**	(2.05)	348	(1.55)	699**	(3.11)	-	-	-	-
	B56A	2103	(9.35)	1169	(5.20)	3185	(14.17)	1346**	(5.99)	934**	(4.15)
120 (3048)	B56	-	-	291	(1.29)	566**	(2.42)	-	-	-	-
	B56A	1703**	(7.57)	1008	(4.48)	2580	(11.47)	1090**	(4.85)	-	-

**Where the slenderness ratio $\frac{KL}{r}$ exceeds 200, and K = end fixity factor, L = actual length and r = radius of gyration.

Reference page 48 for general fitting and standard finish specifications.

Telescoping channel

BTS22TH

- Can be secured at any point of system
- Order BTS22TH separately
- Thickness: 12 Gauge (2.6 mm)
- Standard lengths: 10' (3.05 m)
- Standard finishes: DURA GREEN™, Yellow Zinc Dichromate, Hot-Dipped Galvanized

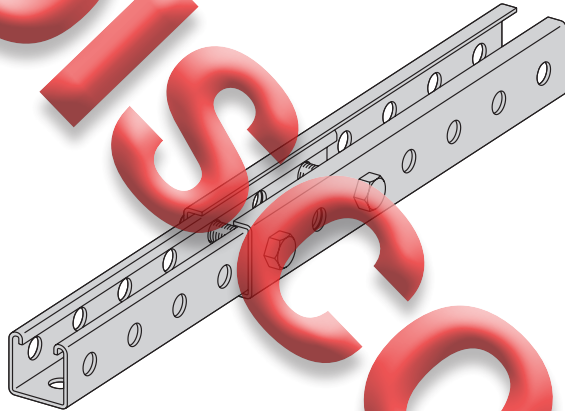

Slip Load Data

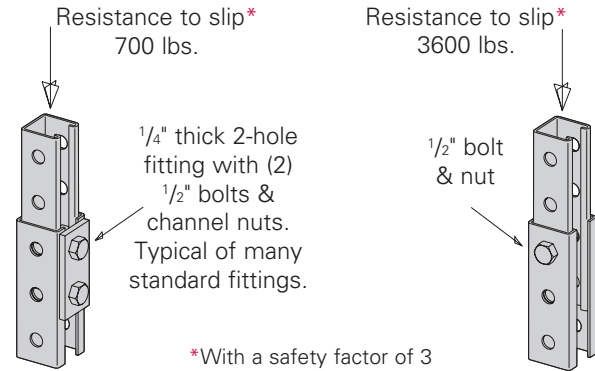

BTS22TH Telescoping Strut

Fits over all 1⁵/₈" x 1⁵/₈" channels ⁹/₁₆" holes on 1⁷/₈" centers. 12 gauge material thickness

Channel	Section Properties		X-X Axis				Y-Y Axis			
	Weight lbs./ft.	Area In ²	Cx In	Ix In ⁴	Sx In ³	rx In	Cy In	Iy In ⁴	Sy In ³	ry In
BTS22TH	1.934	0.4578	1.0009	0.2525	0.2523	0.7426	0.9375	0.2757	0.2941	0.7761

Section properties are based on nominal metal thickness, and overall dimensions.

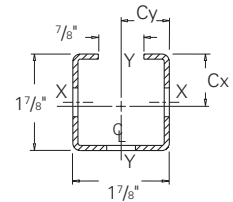

BTS22TH

Beam Span in	Beam Load Data x-x Axis		
	Allowable Load lbs*	Resulting Deflection in	Allowable Load @ Deflection= $1/240$ Span Lbs. kN
12	4203	0.012	4203 (18.69)
24	2099	0.050	2099 (9.33)
36	1396	0.112	1396 (6.21)
48	1044	0.200	1044 (4.64)
60	831	0.312	664 (2.95)
72	689	0.450	456 (2.03)
84	587	0.612	330 (1.48)
96	510	0.799	248 (1.10)
108	450	1.012	190 (0.84)
120	401	1.249	149 (0.66)

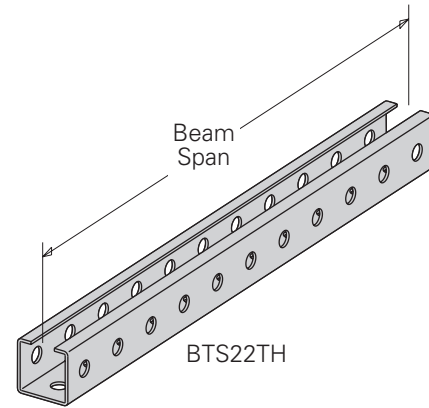

*Based on simple beam condition using an allowable design stress of 25,000 psi (172 MPa) with adequate lateral bracing (see page 12 for further explanation). To determine concentrated load capacity at mid span, multiply uniform load by 0.5 and corresponding deflection by 0.8.

Channel hole patterns

B11SH thru B56SH SH Type Channel

- For beam loads use 90% of Channel Loading Chart

Part No.	Thickness	Height H		Weight	
		In.	mm	Lbs./Ft.	kg/m
B11SH	12 Ga. (2.6)	3 ¹ / ₄ "	(82.5)	2.97	(4.42)
B12SH	12 Ga. (2.6)	2 ⁷ / ₁₆ "	(61.9)	2.39	(3.55)
B22SH	12 Ga. (2.6)	1 ⁵ / ₈ "	(41.3)	1.82	(2.71)
B24SH	14 Ga. (1.9)	1 ⁵ / ₈ "	(41.3)	1.34	(1.99)
B32SH	12 Ga. (2.6)	1 ³ / ₈ "	(34.9)	1.62	(2.41)
B42SH	12 Ga. (2.6)	1"	(25.4)	1.36	(2.02)
B52SH	12 Ga. (2.6)	1 ³ / ₁₆ "	(20.6)	1.19	(1.77)
B54SH	14 Ga. (1.9)	1 ³ / ₁₆ "	(20.6)	.91	(1.35)

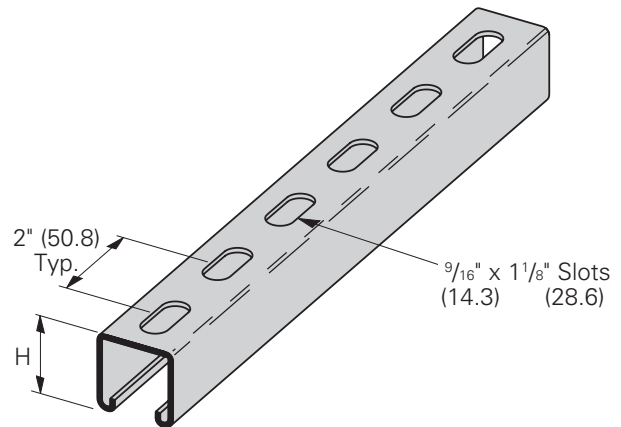

B11S thru B56S S Type Channel

- For beam loads use 90% of Channel Loading Chart

Part No.	Thickness	Height H		Weight	
		In.	mm	Lbs./Ft.	kg/m
B11S	12 Ga. (2.6)	3 ¹ / ₄ "	(82.5)	2.94	(4.37)
B12S	12 Ga. (2.6)	2 ⁷ / ₁₆ "	(61.9)	2.36	(3.51)
B22S	12 Ga. (2.6)	1 ⁵ / ₈ "	(41.3)	1.79	(2.66)
B24S	14 Ga. (1.9)	1 ⁵ / ₈ "	(41.3)	1.32	(1.96)
B32S	12 Ga. (2.6)	1 ³ / ₈ "	(34.9)	1.59	(2.36)
B42S	12 Ga. (2.6)	1"	(25.4)	1.33	(1.98)
B52S	12 Ga. (2.6)	1 ³ / ₁₆ "	(20.6)	1.16	(1.72)
B54S	14 Ga. (1.9)	1 ³ / ₁₆ "	(20.6)	.89	(1.32)

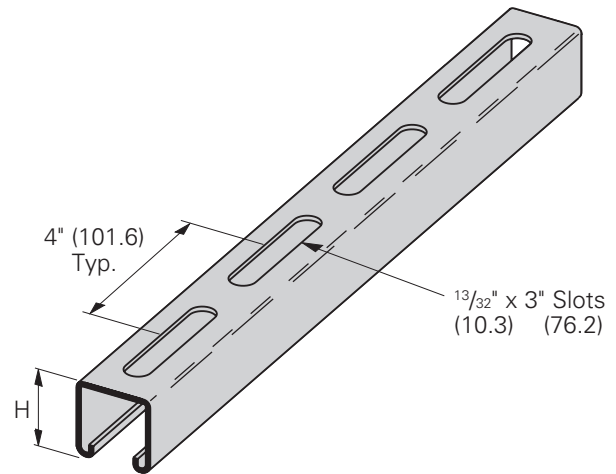

B11H17/8 thru B56H17/8 H17/8 Type Channel

- For beam loads use 90% of Channel Loading Chart

Part No.	Thickness	Height H		Weight	
		In.	mm	Lbs./Ft.	kg/m
B11H17/8	12 Ga. (2.6)	3 ¹ / ₄ "	(82.5)	3.00	(4.46)
B12H17/8	12 Ga. (2.6)	2 ⁷ / ₁₆ "	(61.9)	2.42	(3.60)
B22H17/8	12 Ga. (2.6)	1 ⁵ / ₈ "	(41.3)	1.85	(2.75)
B24H17/8	14 Ga. (1.9)	1 ⁵ / ₈ "	(41.3)	1.36	(2.02)
B32H17/8	12 Ga. (2.6)	1 ³ / ₈ "	(34.9)	1.65	(2.45)
B42H17/8	12 Ga. (2.6)	1"	(25.4)	1.39	(2.07)
B52H17/8	12 Ga. (2.6)	1 ³ / ₁₆ "	(20.6)	1.22	(1.81)
B54H17/8	14 Ga. (1.9)	1 ³ / ₁₆ "	(20.6)	.93	(1.38)

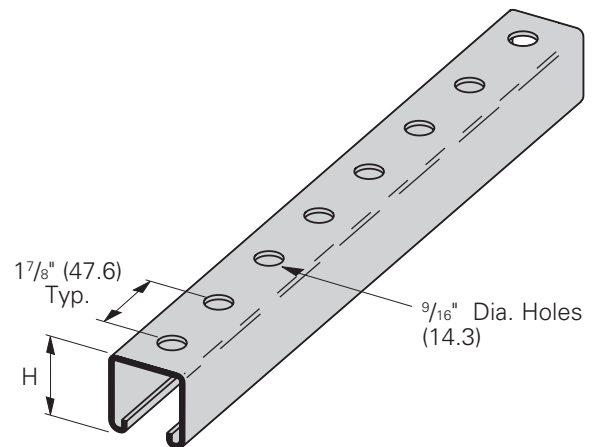

Reference page 48 for general fitting and standard finish specifications.

B22TH TH Type Channel

- For beam loads use 90% of Channel Loading Chart

Part No.	Thickness	Height H In. mm	Weight Lbs./Ft. kg/m
B22TH	12 Ga.(2.6)	1 ⁵ / ₈ " (41.3)	1.76 (2.62)

Beam Loading Data B22TH

Beam Span in	Beam Load Data x-x Axis		
	Allowable Load lbs*	Resulting Deflection in	Allowable Load @ Deflection=1/240 Span Lbs. kN
12	2225	0.015	3225 (14.34)
24	1610	0.061	1610 (7.16)
36	1071	0.136	1071 (4.76)
48	800	0.243	658 (2.92)
60	637	0.379	417 (1.85)
72	528	0.546	286 (1.27)
84	449	0.743	206 (0.91)
96	390	0.970	153 (0.68)
108	344	1.228	116 (0.51)
120	306	1.516	90 (0.40)

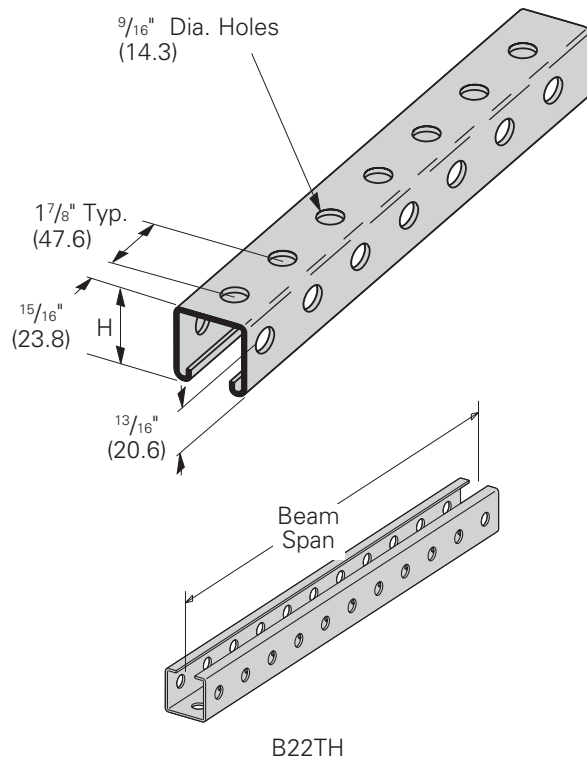

B11KO6 thru B56KO6 KO6 Type Knockout Channel

- For beam loads use 90% of Channel Loading Chart

Part No.	Thickness	Height H In. mm	Weight Lbs./Ft. kg/m
B11KO6	12 Ga. (2.6)	3 ¹ / ₄ " (82.5)	3.05 (4.54)
B12KO6	12 Ga.(2.6)	2 ⁷ / ₁₆ " (61.9)	2.47 (3.67)
B22KO6	12 Ga.(2.6)	1 ⁵ / ₈ " (41.3)	1.90 (2.83)
B24KO6	14 Ga.(1.9)	1 ⁵ / ₈ " (41.3)	1.40 (2.08)
B32KO6	12 Ga.(2.6)	1 ³ / ₈ " (34.9)	1.70 (2.53)
B42KO6	12 Ga.(2.6)	1" (25.4)	1.44 (2.14)
B52KO6	12 Ga.(2.6)	1 ³ / ₁₆ " (20.6)	1.27 (1.89)
B54KO6	14 Ga.(1.9)	1 ³ / ₁₆ " (20.6)	.97 (1.44)

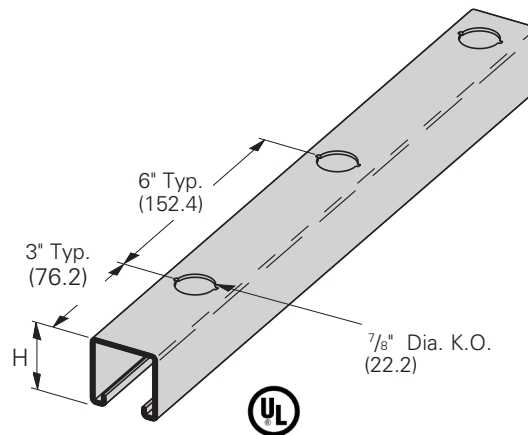

B22SHA Back to Back SH Type Channel

- For beam loads use 90% of Channel Loading Chart

Part No.	Thickness	Height H In. mm	Weight Lbs./Ft. kg/m
B22SHA	12 Ga.(2.6)	3 ¹ / ₄ " (82.5)	3.64 (5.42)
B52SHA	12 Ga.(2.6)	1 ⁵ / ₈ " (41.3)	2.38 (1.77)
B54SHA	14 Ga.(1.9)	1 ⁵ / ₈ " (41.3)	1.82 (1.35)

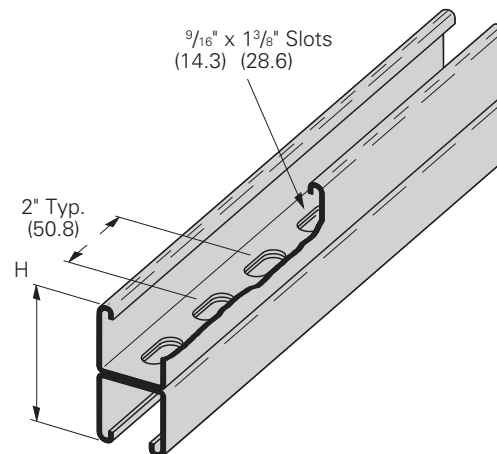

Reference page 48 for general fitting and standard finish specifications.

Channel hole patterns

B11S58 thru B56S58 S58 Type Channel

- For beam loads use 90% of Channel Loading Chart

Part No.	Thickness	Height H		Weight	
		In.	mm	Lbs./Ft.	kg/m
B11S58	12 Ga. (2.6)	3 ¹ / ₄ "	(82.5)	2.94	(4.37)
B12S58	12 Ga. (2.6)	2 ⁷ / ₁₆ "	(61.9)	2.36	(3.51)
B22S58	12 Ga. (2.6)	1 ⁵ / ₈ "	(41.3)	1.79	(2.66)
B24S58	14 Ga. (1.9)	1 ⁵ / ₈ "	(41.3)	1.32	(1.96)
B32S58	12 Ga. (2.6)	1 ³ / ₈ "	(34.9)	1.59	(2.36)
B42S58	12 Ga. (2.6)	1"	(25.4)	1.33	(1.98)
B52S58	12 Ga. (2.6)	1 ³ / ₁₆ "	(20.6)	1.16	(1.72)
B54S58	14 Ga. (1.9)	1 ³ / ₁₆ "	(20.6)	.89	(1.32)

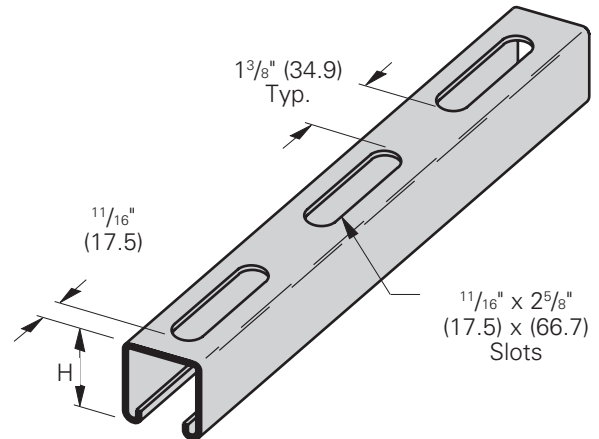

B22M thru B54M M (Marine Rung) Type Channel

- For beam loads use 90% of Channel Loading Chart

Part No.	Thickness	Height H		Weight	
		In.	mm	Lbs./Ft.	kg/m
B22M	12 Ga. (2.6)	1 ⁵ / ₈ "	(41.3)	1.79	(2.66)
B24M	14 Ga. (1.9)	1 ⁵ / ₈ "	(41.3)	1.32	(1.96)
B32M	12 Ga. (2.6)	1 ³ / ₈ "	(34.9)	1.59	(2.36)
B42M	12 Ga. (2.6)	1"	(25.4)	1.33	(1.98)
B44M	14 Ga. (1.9)	1"	(25.4)	0.98	(1.46)
B52M	12 Ga. (2.6)	1 ³ / ₁₆ "	(20.6)	1.16	(1.72)
B54M	14 Ga. (1.9)	1 ³ / ₁₆ "	(20.6)	.89	(1.32)

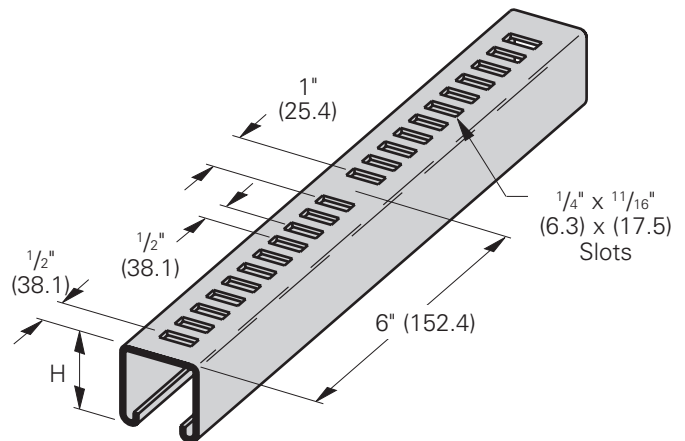

B22H25 thru B56H25 H25 Type Channel

- For beam loads use 90% of Channel Loading Chart

Part No.	Thickness	Height H		Weight	
		In.	mm	Lbs./Ft.	kg/m
B22H25	12 Ga. (2.6)	1 ⁵ / ₈ "	(41.3)	1.85	(2.75)
B24H25	14 Ga. (1.9)	1 ⁵ / ₈ "	(41.3)	1.36	(2.02)
B32H25	12 Ga. (2.6)	1 ³ / ₈ "	(34.9)	1.65	(2.45)
B42H25	12 Ga. (2.6)	1"	(25.4)	1.39	(2.07)
B52H25	12 Ga. (2.6)	1 ³ / ₁₆ "	(20.6)	1.22	(1.81)
B54H25	14 Ga. (1.9)	1 ³ / ₁₆ "	(20.6)	.93	(1.38)

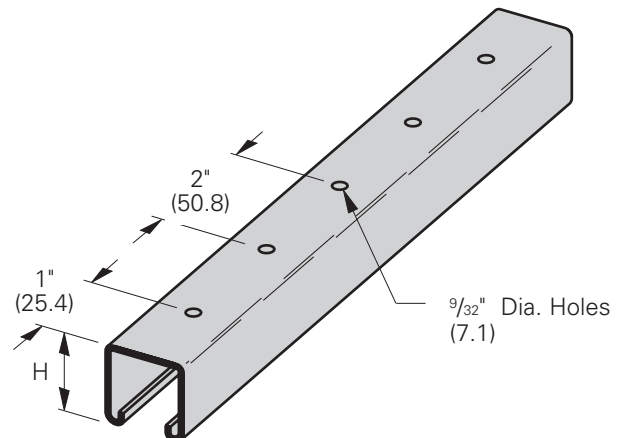

Reference page 48 for general fitting and standard finish specifications.

B217-20 Snap Closure Strip for All 1⁵/₈" (41.3) Wide Channels

- Refer to Raceway Fill Chart pages 278-279
- Material: 20 Gauge (.9)
- Standard finishes: GRN, GALV, YZN
- Standard length: 120" (3.05m)
- Wt./CFT 36 Lbs. (16.3 kg)

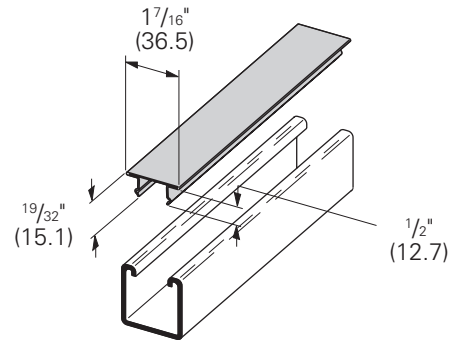

B217P Plastic Snap Closure Strip for All 1⁵/₈" (41.3) Wide Channels

- Refer to Raceway Fill Chart pages 278-279
- Standard finishes: Green (GRN) or Gray (GRY) Plastic
- Standard length: 120" (3.05m)
- Wt./CFT 9.2 Lbs. (4.2 kg)

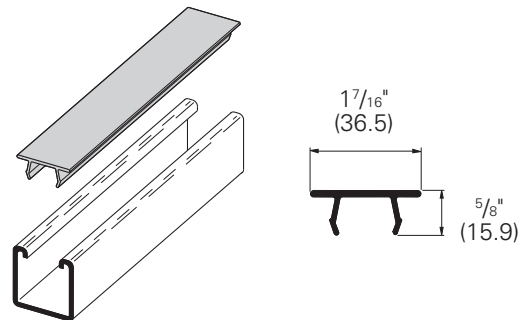

B217-24 Snap Closure Strip for All 1⁵/₈" (41.3) Wide Channels

- Refer to Raceway Fill Chart pages 278-279
- For use with 7 or fewer conductors no larger than #12 AWG
- Material: 24 Gauge (.6)
- Standard finishes: GRN, GALV, YZN
- Standard length: 120" (3.05m)
- Wt./CFT 28 Lbs. (12.7 kg)

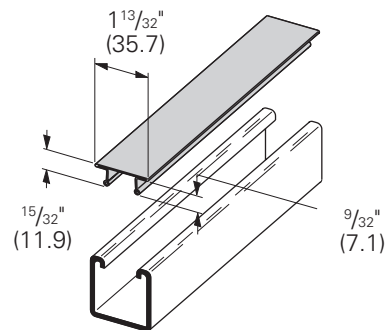

Touch Up Paint

- Used to touch up cut ends of channel
- Standard colors: Green for DURA GREEN™ & B999 for Zinc/Galv
- Weight: 12.5 ounce cans

Part No.	Description	Box Qty.
B999	Zinc/Galv color	1
940-674A	Dura-Green color	1



B999



940-674A

Reference page 48 for general fitting and standard finish specifications.

Hydraulic Strut Cutter

- Patented **esp*** hydraulic strut cutter easily cuts a variety of B-Line series strut profiles to size in seconds
- Produces clean cuts without burrs or sharp edges - no post processing necessary
- Lightweight, black anodized 7075-T651 aluminum frame is portable to the jobsite - 65 lbs. (29.4kg)
- Collapsible handle creates a sturdy operations platform
- 10,000psi hydraulic power source and hose with universal coupling (sold separately) required for operation
- Adjustable material rest* feeds strut sections straight into cutter
- Adjustable backstop* provides for easy production cutting
- Die sets available for cutting B22, B24, B26, B52, B54, B56 strut profiles
- Die life: thousands of cuts from a single set of blades

*requires two (2) sections of 1" OD tubing - sold separately



* **esp** (edwards strut pro) is a product logo used by Edwards Manufacturing Company

Part No.	Description	Wt./C	
		Lbs.	kg
BHSC100	Complete esp set includes cutter, hydraulic pump & hose, material rest, backstop and the three (3) die sets listed below	173	(78.5)
Die Sets for Channel			
BHSC100B22	B22, B24, B26, B52, B54, B56	13	(5.9)

